



Platform to Powertrain Electrical Interface (PPEI) Specification Cruise Control Subsystem

1 Introduction

This standard defines the Cruise Control electrical interface between Platform and Powertrain.

1.1 Applicability.

The **GMW8762** PPEI (Platform to Powertrain Electrical Interface) Standard Specification includes: General Information, On-Board Diagnostics and Electrical Requirements and GMLAN Serial Data Signal Definitions and Framing for the following nineteen PPEI subsystems standard specifications:

1. **GMW8763** Power and Ground
2. **GMW8764** Four Wheel Drive/All Wheel Drive Controls
3. **GMW8765** Displays and Gauges
4. **GMW8766** Engine Power Management
5. **GMW8767** Starter Control
6. **GMW8768** Vehicle Theft Deterrent
7. **GMW8769** Cruise Control
8. **GMW8770** Cooling Fan Control
9. **GMW8771** Air Conditioning Compressor Control
10. **GMW8772** Serial Data Architecture
11. **GMW8773** Brakes and Traction Control
12. **GMW8774** Enhanced Evaporative Emissions and Fuel
13. **GMW8775** Exhaust After-Treatment
14. **GMW8776** Suspension Control
15. **GMW8777** Transmission
16. **GMW8778** Generator Control
17. **GMW8779** Post Collision Operation
18. **GMW8780** Power Take-Off and Fast Idle Control
19. **GMW8781** Vehicle Speed and Rough Road Sensing

Each of the nineteen PPEI subsystem standard specifications contains the hardware, serial data, algorithms and calibrations for the named subsystem.

The master PPEI document and all nineteen PPEI subsystem standard specifications are required to define the complete set of PPEI requirements.

2 References

Note: Only the latest approved standards are applicable unless otherwise specified.

2.1 External Standards/Specifications.

None.

2.2 GM Standards/Specifications.

GMW3001	GMW8772
GMW3059	GMW8773
GMW8762	GMW8774
GMW8763	GMW8775
GMW8764	GMW8776
GMW8765	GMW8777
GMW8766	GMW8778
GMW8767	GMW8779
GMW8768	GMW8780
GMW8770	GMW8781
GMW8771	

2.3 Additional References.

GMPT Cruise Control Subsystem Technical Specification (SSTS)

Adaptive Cruise Control Subsystem Technical Specification (SSTS)

3 Subsystem Requirements

3.1 Functional Overview.

The interface defined in this section shall apply specifically to the following subsystems relating to throttle control:

- Conventional Cruise Control
- Adaptive Cruise Control (ACC)

3.1.1 Conventional Cruise Control.

Conventional Cruise Control shall control the vehicle speed to an operator selectable speed. The operator shall apply cruise mode switches to enable and engage cruise as well as select and

adjust the driver-selected speed. The cruise control subsystem shall control to the driver-selected speed using the ETC subsystem. The disabling and disengagement of the subsystem is affected via operator application of the brake pedal, On/Off switch, clutch switch or Clutch Pedal Position sensor (manual transmission only), as well as other defined disengagement criteria.

The cruise mode switches shall interface to a platform module, which forwards the switch states to the ECM via GMLAN signals. The interpretation of the cruise mode switches, associated moding and closed loop control shall reside within the ECM. The brake pedal apply sensing shall be provided by the platform via both a discrete input and a GMLAN signal to the ECM.

3.1.2 Adaptive Cruise Control (ACC).

Adaptive Cruise Control maintains a driver selected vehicle speed or maintains a driver adjustable headway to a preceding licensable vehicle moving slower than the driver selected vehicle speed. ACC automatically switches between speed control and headway control. Headway control and speed control are accomplished by requesting limited automatic braking or using the ETC subsystem for throttle control.

The ACC function includes features that allow the driver to:

- a) Engage the ACC function
- b) Select the maximum vehicle speed (driver selected speed) to be maintained while ACC is engaged
- c) Adjust the headway to be maintained to a preceding licensable vehicle moving slower than the driver selected vehicle speed
- d) Override the ACC vehicle speed control using the accelerator pedal
- e) Disengage the ACC function using On/Off switch or depression of brake pedal, as well as other defined disengagement criteria..

The cruise mode switches shall interface to a platform module, which forwards the switch states to both the ACC module and ECM via GMLAN signals. The brake pedal apply sensing shall be provided by a platform module via a GMLAN signal to the ACC module and ECM. Additionally, a discrete input indicating brake pedal apply state shall be provided to the ECM. The ECM shall

transmit a GMLAN signal indicating the state of the discrete brake signal to the ACC module. The interpretation of the cruise mode switches, and associated moding shall reside within the ACC module.

The ACC module determines a desired vehicle response and forwards an appropriate request to the ECM in the form of a vehicle acceleration (deceleration if the value is negative).

Note, this acceleration request does not reflect the absolute vehicle acceleration level desired. This acceleration request shall be modified as necessary to comprehend external disturbances, such as road grade, wind, vehicle mass variation, etc.

The ECM converts the acceleration value to an axle torque request and delivers torque accordingly. This conversion within the ECM is an open-loop translation. The ECM does not modify this conversion based on any external disturbances. For example if the vehicle is climbing a hill, a given acceleration request will be translated to the same axle torque that would be calculated on a level road.

The ECM requires a vehicle model to translate the vehicle acceleration request to an axle torque. The vehicle model contains vehicle specific characteristics such as effective tire rolling radius, vehicle mass, rolling resistance, and aerodynamic coefficients.

The platform is responsible for providing a calibration value reflecting the vehicle mass, to be located in the ECM. The mass will typically reflect the mass of the vehicle with just the driver present.

This document does not comprehend ACC applications with manual transmissions, as there are currently no such applications.

The ECM as part of a rationality check shall monitor several key signals. The ECM processing this information redundant to the ACC module enhances the system's robustness. The signals monitored shall include key enable and disengagement criteria, such as the cruise switch states, brake pedal apply states and vehicle speed. The rationality check must successfully pass prior to the ECM responding to an ACC request for throttle control. If the ECM determines a signal is in a state where ACC should be disengaged, the ECM shall execute a disengagement as well as communicate the disengagement to the ACC module using the Adaptive Cruise Control Powertrain Inhibit Request signal.

3.2 Hardware Overview.

The electrical interface between the Platform Electronics and the Powertrain Electronics for the Cruise Control Subsystem consists of the serial data link and two inputs. One input is the Brake Pedal Apply input, which is defined in GMW8773 Section 3 PPEI Brakes and Traction Control subsystem Requirements. The second input is a Top-of-Travel Clutch Switch or Clutch Pedal Position sensor, which is required with manual

transmission vehicles with cruise control and not present with automatic transmissions

3.2.1 Block Diagram.

The following block diagram (Figure 1) depicts the mechanization for Conventional Cruise Control and Adaptive Cruise Control. The mechanization is not intended to specify the entire subsystem mechanization but rather aspects crossing the PPEI boundary. The electrical interface between Powertrain and Platform is the only standard defined.

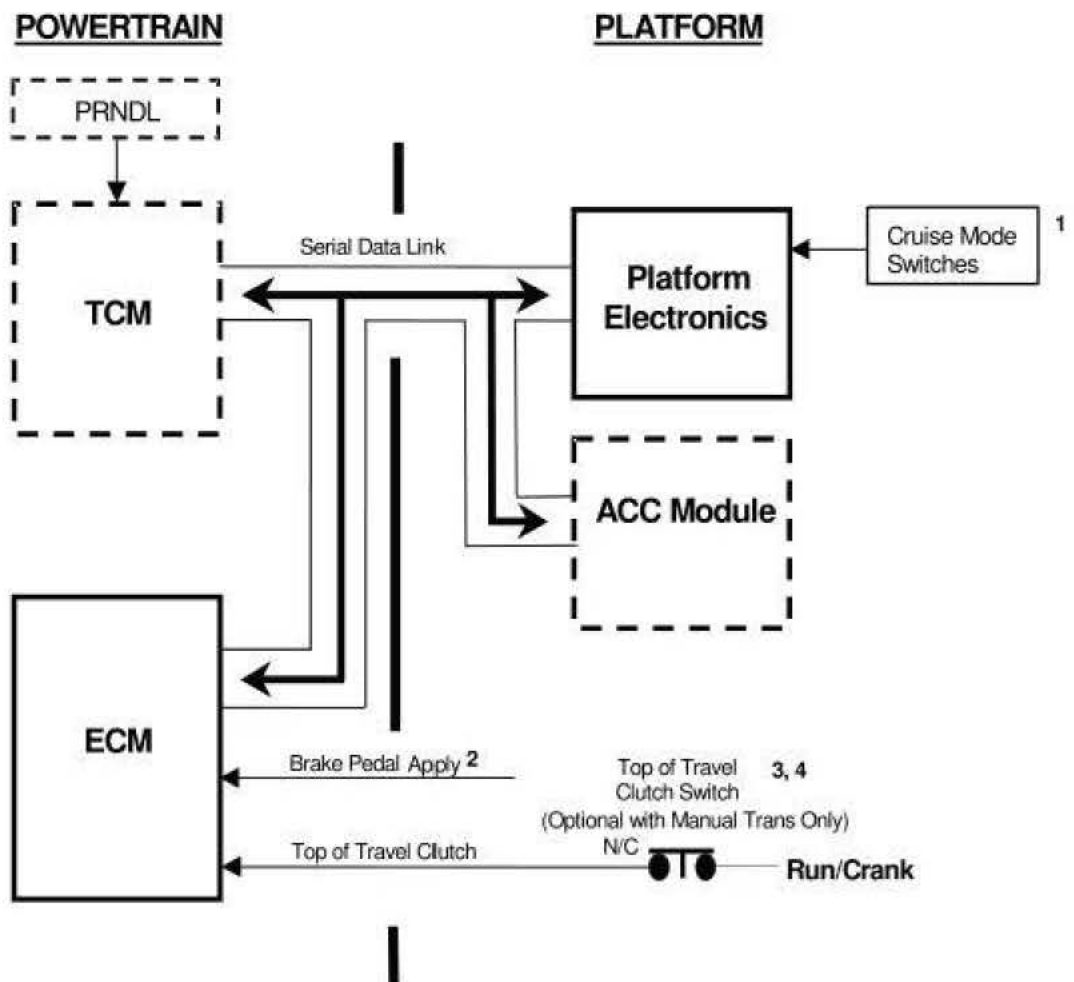

Notes:

1. See GMW8769 Section 3.3.5 for requirements on Cruise Mode Switches.
2. See GMW8773 Section 3.3.3 for more details on Brake Pedal Apply signal.
3. See GMW8769 Section 3.3.4 Top of Travel Clutch.
4. Alternatively a Clutch Pedal Position Sensor may provide this information. Reference GMW8777 for more details.

Figure 1: Conventional and Adaptive Cruise Control Block Diagram

3.3 Interface Description.**3.3.1 Serial Data Link.**

Reference GMW8762 Section 4 PPEI GMLAN Serial Data Signal and Definitions and Framing for definitions of signals listed in Table 1.

3.3.2 Calibrations.

The Cruise Control calibrations that cross the Platform – Powertrain Electrical Interface (i.e., are located in devices on one side of the interface but controlled by the other side of the interface or driven by variation in the other side of the interface) are located in Table 2. Refer to Section 4 for calibration details.

Table 1: Cruise Control Serial Data Signals

Signal Name	Transmitter	Notes
Adaptive Cruise Control Active	Platform	Required with ACC
Adaptive Cruise Control Braking Active	Platform	Required with ABS
Adaptive Cruise Control Command	Platform	Required with ACC
Adaptive Cruise Control Command Alive Rolling Count	Platform	Required with ACC
Adaptive Cruise Control Command Protection	Platform	Required with ACC
Adaptive Cruise Control Powertrain Acceleration Request Superceded	Powertrain	Required
Adaptive Cruise Control Powertrain Inhibit Request	Powertrain	Required
Adaptive Cruise Control Transmission Gear Request	Powertrain	Required
Apply Brake Before Cruise Indication On	Powertrain	Required
Automatic Transmission Commanded Gear	Powertrain	Required
Brake Pedal Driver Applied Pressure Detected	Platform	Required with ABS
Brake Pedal Driver Applied Pressure Detected Validity	Platform	Required with ABS
Brake Pedal Initial Travel Achieved Status	Platform	Required
Brake Pedal Initial Travel Achieved Protection	Platform	Required
Brake Pedal Position Alive Rolling Count	Platform	Required
Cruise Control Active	Powertrain	Required
Cruise Control Cancel Request	Platform	Required
Cruise Control Driver Selected Speed	Powertrain	Required
Cruise Control Driver Selected Speed Active	Powertrain	Required
Cruise Control Enabled	Powertrain	Required
Cruise Control Switch Status	Platform	Required
Cruise Control Switch Status Alive Rolling Count	Platform	Required
Cruise Control Switch Status Protection Value	Platform	Required
Display Measurement System	Platform	Required
Driver Throttle Override Detected	Powertrain	Required
Driver Throttle Override Detected Protection Value	Powertrain	Required
Driver Throttle Override Detection Alive Rolling Count	Powertrain	Required

© Copyright 2006 General Motors Corporation All Rights Reserved

Signal Name	Transmitter	Notes
Engine Speed	Powertrain	Required
Engine Speed Status	Powertrain	Required
Engine Torque Actual Extended Range	Powertrain	Required
Engine Torque Actual Extended Range Validity	Powertrain	Required
Park Brake Switch Active	Platform	Required
Park Brake Virtual Device Availability	Platform	Required
Power Take Off Active	Platform	Required
Powertrain Brake Pedal Discrete Input Status	Powertrain	Required
Powertrain Brake Pedal Discrete Input Status Validity	Powertrain	Required
Top of Travel Clutch Switch Active	Powertrain	Required
Top of Travel Clutch Switch Active Validity	Powertrain	Required
Traction Control System Active	Platform	Required with ABS
Traction Control System Present	Platform	Required with ABS
Transmission Estimated Gear	Powertrain	Required
Transmission Estimated Gear Validity	Powertrain	Required
Transmission Overall Estimated Torque Ratio and Validity	Powertrain	Required
Transmission Overall Estimated Torque Ratio Validity	Powertrain	Required
Vehicle Deceleration Engine Torque Minimum Extended Range	Powertrain	Required
Vehicle Deceleration Engine Torque Minimum Extended Range Validity	Powertrain	Required
Vehicle Speed Average Driven	Powertrain	Required
Vehicle Speed Average Driven Source	Powertrain	Required
Vehicle Speed Average Driven Validity	Powertrain	Required
Vehicle Speed Average Non Driven	Powertrain	Required
Vehicle Speed Average Non Driven Validity	Powertrain	Required
Vehicle Speed Control System Type	Platform	Required
Vehicle Stability Enhancement System Active	Platform	Required with ABS
Vehicle Stability Enhancement System Present	Platform	Required
Wheel Rotational Status Left Driven	Platform	Required with ABS
Wheel Rotational Status Right Driven	Platform	Required with ABS
Wheel Rotational Status Left Non Driven	Platform	Required with ABS
Wheel Rotational Status Right Non Driven	Platform	Required with ABS

Table 2: Cruise Control Calibrations

Calibration Name	Location	Owner
K_AccDisengageDelay	Powertrain	Platform
K_AccLowSpeedDisengage	Powertrain	Platform
K_CruzCruiseSysType	Powertrain	Platform
K_EffctvTireRollingRadius	Powertrain	Platform
K_MetricTapIncrementEnable	Powertrain	Platform
K_OpelCruiseControl	Powertrain	Platform
K_VehicleCurbMass	Powertrain	Platform
K_VehicleMassEst	Powertrain	Platform

3.3.3 Brake Pedal Apply Sensing.

A brake pedal apply shall be communicated via two mechanisms. The first method is a GMLAN signal Brake Pedal Initial Travel Achieved Status. The second is a discrete input to the ECM, Brake Pedal Apply. There shall be no undetectable single point failure, which shall prevent detection of driver application of the brake pedal.

3.3.3.1 Brake Pedal Apply.

This input shall indicate whether the brake pedal is applied or not and is not necessarily indicative of the stop lamps being on. Specific details of the input are defined in GMW8773 Section 3 PPEI Brakes and Traction Control Subsystem Requirements. This input is in addition to a GMLAN signal Brake Pedal Initial Travel Achieved Status indicating brake pedal apply. On vehicles with discrete brake switches, the brake switch used to generate the discrete input shall be a separate switch from the one used to generate the GMLAN signal.

In dual processor ETC subsystems the brake pedal apply discrete input shall be connected directly to both processors. This offers system protection from a single point failure preventing cruise disengagement.

On vehicles with two brake switches, both brake switches shall be designed to indicate brake pedal apply prior to the onset of braking or as close as possible, allowing for tolerance stack-ups.

On vehicles without BAS, the application software in the module processing the switch input shall provide appropriate debounce logic. Consult the switch supplier for applicable debounce requirements (typically 10 ms). The debounce time shall allow for the maximum switch bounce time plus any margin deemed necessary. Any change of state lasting less than the determined debounce

time shall be ignored. The software shall require at least two successive reads of the input reflecting the new state before recognizing the change of state as valid. Depending on the sample time, more than two successive reads can be applied.

The maximum Input Delay shall not exceed 35 ms. The input delay is defined as the time from when the switch initially changes state until the discrete output reflects the new state. The input delay includes any debounce time.

The maximum Output Actuation Delay shall not exceed 25 ms. The output actuation delay is defined as the time from when the discrete input Brake Pedal Apply changes state until the cruise application software begins commanding a resulting throttle position.

Cruise control implementations shall address the "Brake Before Cruise" algorithm. Both the Brake Pedal Apply discrete and the GMLAN signal Brake Pedal Initial Travel Achieved Status shall be seen in the pedal applied state on each ignition cycle before allowing cruise control to be engaged. This is to verify proper operation of the brake switches/sensor before cruise can be enabled. The "Brake Before Cruise" algorithm shall reside in the ECM for conventional cruise applications and in the ACC module for ACC applications.

3.3.4 Top of Travel Clutch.

The Top of Travel Clutch switch and Clutch Pedal Position sensor are optional on manual transmission applications only. The switch or sensor is mandatory for all vehicles equipped with cruise control and also for all North American Applications even if these applications are released in the non North American markets. However, the switch or sensor is optional for non North American applications not equipped with cruise control.

Powertrain uses top of travel clutch information for disabling cruise control when the clutch pedal is depressed and may be used for idle speed control, and enhancing the determination of gear information.

3.3.4.1 Top of Travel Clutch switch

This switch is a momentary contact normally closed switch to Run/Crank voltage. The Clutch switch opens when the operator depresses the clutch pedal.

3.3.4.2 Clutch Pedal Position (CPP) Sensor.

A potentiometer provides an indication of the clutch pedal position. The ECM uses this input to determine the current pedal position relative to the total range of pedal travel available on a vehicle.

3.3.5 Cruise Mode Switches.

A platform module shall read the cruise control mode switches and transmit their states via GMLAN signals. Two methods currently exist for mechanizing the cruise control mode switches, analog (multiplexed) and discrete.

3.3.5.1 Discrete Switch Architecture.

On applications with discrete switches the application software reading the switch input shall provide appropriate debounce logic. Consult the switch supplier for applicable bounce requirements (typically 10 ms). The debounce time shall allow for the maximum switch bounce time plus any margin deemed necessary. Any change of state lasting less than the determined debounce time shall be ignored. The software shall require at least two successive reads of the input reflecting the new state before recognizing the change of state as valid. Depending on the sample time, more than two successive reads can be applied.

Additionally, each discrete cruise control mode switch shall be debounced independently (i.e., an intermittent bounce on one signal should not preclude recognition of a valid change of state on another switch).

3.3.5.2 Analog Switch Architecture.

The application software reading the switch input shall apply appropriate filtering.

A multiplexed input can only represent one switch as being active at a time, either ON, SET, RESUME or CANCEL. Conversely, a discrete system can have multiple switch inputs active simultaneously since each switch has a dedicated input, e.g. ON and SET or ON and RESUME. The interpretation of the cruise modes within the cruise control software has been based upon a discrete architecture where the ON switch can be recognized as active simultaneously whenever the

SET or RESUME switch is active. To maintain common software the Gateway (GW) on a multiplexed cruise switch architecture is expected to indicate the ON switch is active whenever indicating the SET or RESUME switches are active. Upon the release of the SET or RESUME switch the GW is to revert back to indicating the current ON/OFF switch state based upon the multiplexed input voltage, whether ON or OFF.

3.3.5.3 Mapping of Physical Cruise Control Mode Switches to GMLAN Mode Switch Signals.

There are three configurations of cruise control mode switches currently supported. Reference Table 3.

The three configurations allow for application unique interfaces between the customer and the cruise control function. The gateway module is responsible for monitoring the switch states and relaying the information to the ECM via a common set of GMLAN signals.

The GMLAN signals used to communicate the cruise control mode switch states are located in Table 4.

Example 1:

When the Set/Coast switch is applied in a North American application.

Cruise Control Switch Status: Set Switch Active = "True"

Cruise Control Switch Status: Speed Decrease Switch Active = "True"

Example 2:

When the Set/Accel switch is applied in an Opel application.

Cruise Control Switch Status: Set Switch Active = "True"

Cruise Control Switch Status: Speed Increase Switch Active = "True"

Diagnostics and further details associated with processing the cruise mode switches are located in Section 4 Cruise Control Algorithm Requirements.

On vehicles where a cruise control option is not present (Vehicle Speed Control System Type signal is "No Vehicle Speed Control"), the Gateway shall transmit the state of each cruise mode switch as being inactive, "False".

Maximum Input Delay = 50 ms

Maximum Actuator Output Delay = 25 ms

Note: The implementation of the cruise mode switches is safety critical, and must be the subject of a detailed subsystem-wide Failure Mode and Effects Analysis. There are currently two acceptable methods for a platform to implement

the mode switches. These methods are documented in the "GMPT Cruise Control Subsystem Technical Specification." This document contains information such as a detailed

electrical mechanization, tolerances of electrical components, system voltage range and noise, offset voltage between switch supply voltage and module reference voltage, signal coherency, etc.

Table 3: Cruise Control Mode Switches Configurations

North America	Opel	Saab
On/Off		On/Off
Set/Coast	Set/Accel	Set/Coast
Resume/Accel	Resume/Coast	Set/Accel
Cancel (optional)	Cancel	Cancel (optional)
		Resume

Table 4: Cruise Control mode Switch States – GMLAN Signals

Signal	Length	Data Type	Conversion
Cruise Control Switch Status	8	PKT	N/A
Cancel Switch Active	1	BLN	\$1=True; \$0=False
On Switch Active	1	BLN	\$1=True; \$0=False
Resume Switch Active	1	BLN	\$1=True; \$0=False
Set Switch Active	1	BLN	\$1=True; \$0=False
Speed Increase Switch Active	1	BLN	\$1=True; \$0=False
Speed Decrease Switch Active	1	BLN	\$1=True; \$0=False
Switch Data Integrity	2	ENM	\$0 = Data Valid \$1 = Data Invalid \$2 = Failure Detected

3.3.6 Vehicle Speed.

Cruise control requires vehicle speed information. Two sources exist for vehicle speed. One source is TOSS (Transmission Output Speed Sensor). The second source is wheel speed sensors. Information from the wheel speed sensors is contained in the GMLAN Wheel Rotational Status signals. The vehicle speed derived from TOSS may be made available in the GMLAN signal Vehicle Speed Average Driven. Further details can be located in Section 4 Cruise Control Algorithm Requirements.

3.4 Failure Modes and Diagnostics.

Reference GMW8772 Section 3.4 PPEI Serial Data Architecture Requirements for serial data failure modes and diagnostic information.

Platform and Powertrain shall provide appropriate diagnostics and failsofts for each of their inputs and outputs. Further details regarding diagnostics can be located in Section 4. The diagnostics shall comply with the requirements specified in the appropriate document, "GMPT Cruise Control

Subsystem Technical Specification" or "Adaptive Cruise Control Subsystem Technical Specification".

3.5 Electrical Characteristics.

3.5.1 Brake Pedal Apply.

Reference GMW8773 Section 3.5.1 PPEI Brakes and Traction Control Subsystem.

3.5.2 Top of Travel Clutch.

3.5.2.1 Top of Travel Clutch Switch.

The top of travel clutch switch is a normally closed switch, sourced by Run/Crank, which opens when the clutch is depressed.

Reference GMW8762 Section 3.3.2 PPEI Electrical Requirements for details.

3.5.2.2 Clutch Pedal Position (CPP) Sensor.

The CPP sensor shall be a potentiometer with a resistance of 3k Ohm between the CPP Vref and CPP Rtn terminals .

Reference GMW8777 section 3.5.2.2 CPPS Electrical Requirements for details.

4 Validation

4.1 Cruise Control Algorithm Requirements

4.1.1 General Overview.

4.1.1.1 Conventional Cruise Control.

Conventional cruise control shall control the vehicle speed to a driver-selected speed. The driver-selected speed is determined by operator application of the cruise control mode switches. Mode switches are also used to enable and engage cruise control. The disabling and disengagement of the subsystem is affected via operator application of the brake pedal, On/Off switch, clutch switch or Clutch Pedal Position (CPP) Sensor (manual transmission only), as well as other defined operating conditions.

The cruise mode switches shall interface to a platform module, which forwards the switch states to the ECM via GMLAN signals. The interpretation of the cruise mode switches, associated moding and closed loop control shall reside within the ECM. The brake apply sensing shall be provided by the brake sensing module via both a discrete input and a GMLAN signal to the ECM.

4.1.1.2 Adaptive Cruise Control.

Adaptive Cruise Control maintains a driver selected vehicle speed or maintains a driver adjustable headway to a preceding licensable vehicle moving slower than the driver selected vehicle speed. ACC automatically switches between speed control and headway control. Headway control and speed control are accomplished by requesting limited automatic braking or using the ETC subsystem for throttle control.

The ACC module determines a desired vehicle response and forwards a request to the ECM in the form of a vehicle acceleration (deceleration if the value is negative). Note, this acceleration request does not reflect the absolute vehicle acceleration level desired. This acceleration request shall be modified as necessary via closed loop control in the ACC module to comprehend external disturbances, such as road grade, wind, vehicle mass variation, etc..

The ECM converts the acceleration value to an axle torque request and delivers torque accordingly. This conversion within the ECM is an open-loop translation. The ECM requires a vehicle mass term to translate the Adaptive Cruise Control acceleration request to an axle torque. More details regarding this translation can be located in Section 4.1.4.2.3 Conversion of Acceleration.

The ECM as part of a rationality check shall monitor several key signals before allowing throttle control to the ACC subsystem. More details regarding this function can be located in Section 4.1.4.2.1 ACC Supervisory Function.

4.1.1.3 Serial Data Requirements.

The serial data link is the primary interface between the Platform and Powertrain controllers. The signals that are communicated are listed here. Complete definitions can be found in GMW8762 Section 4 PPEI GMLAN Serial Data Signal and Definitions and Framing.

4.1.1.3.1 GMLAN Signals Sent by Powertrain.

- a. The following signal information shall be transmitted by the ECM. These signals shall be received and processed by the Platform electronics.
 - (1) Adaptive Cruise Control Powertrain Acceleration Request Superseded
 - (2) Adaptive Cruise Control Powertrain Inhibit Request
 - (3) Apply Brake Before Cruise Indication On
 - (4) Cruise Control Active
 - (5) Cruise Control Driver Selected Speed
 - (6) Cruise Control Driver Selected Speed Active
 - (7) Cruise Control Enabled
 - (8) Driver Throttle Override Detected
 - (9) Driver Throttle Override Detected Protection Value
 - (10) Driver Throttle Override Detection Alive Rolling Count
 - (11) Engine Speed

- (12) Engine Speed Status
 - (13) Engine Torque Actual Extended Range
 - (14) Engine Torque Actual Extended Range Validity
 - (15) Powertrain Brake Pedal Discrete Input Status
 - (16) Powertrain Brake Pedal Discrete Input Status Validity
 - (17) Top of Travel Clutch Switch Active
 - (18) Top of Travel Clutch Switch Active Validity
 - (19) Vehicle Deceleration Engine Torque Minimum Extended Range
 - (20) Vehicle Deceleration Engine Torque Minimum Extended Range Validity
 - (21) Vehicle Speed Average Driven
 - (22) Vehicle Speed Average Driven Source
 - (23) Vehicle Speed Average Driven Validity
 - (24) Vehicle Speed Average Non Driven
 - (25) Vehicle Speed Average Non Driven Validity
- b. The following signal information shall be transmitted by the TCM when a TCM is present or otherwise by the ECM when a TCM is not present. These signals shall be received and processed by the Platform electronics.
- (1) Automatic Transmission Commanded Gear
 - (2) Transmission Estimated Gear
 - (3) Transmission Estimated Gear Validity
 - (4) Transmission Overall Estimated Torque Ratio

4.1.1.3.2 GMLAN Signals Sent by Platform.

- a. The following signals shall be transmitted by the ACC module. These signals shall be received and processed by the Powertrain electronics.
- (1) Adaptive Cruise Control Active
 - (2) Adaptive Cruise Control Command
 - (3) Adaptive Cruise Control Command Alive Rolling Count
 - (4) Adaptive Cruise Control Command Protection
 - (5) Adaptive Cruise Control Transmission Gear Request
- b. The following signals shall be transmitted by the Gateway module. These signals shall be received and processed by the Powertrain electronics.
- (1) Cruise Control Cancel Request
 - (2) Cruise Control Switch Status
 - (3) Cruise Control Switch Status Alive Rolling Count
 - (4) Cruise Control Switch Status Protection Value
 - (5) Park Brake Switch Active
 - (6) Park Brake Virtual Device Availability
 - (7) Vehicle Speed Control System Type
 - (8) Vehicle Stability Enhancement System Present
- c. The following signals shall be transmitted by the Brake Sensing module. These signals shall be received and processed by the Powertrain electronics.
- (1) Brake Pedal Initial Travel Achieved Status
 - (2) Brake Pedal Initial Travel Achieved Protection
 - (3) Brake Pedal Position Alive Rolling Count

- d. The following signals shall be transmitted by the EBCM (Electronic Brake Control Module) when an EBCM module is present; otherwise they are not transmitted. These signals shall be received and processed by the Powertrain electronics.
- (1) Adaptive Cruise Control Braking Active
 - (2) Traction Control System Active
 - (3) Vehicle Stability Enhancement Active
 - (4) Brake Pedal Driver Applied Pressure Detected
 - (5) Brake Pedal Driver Applied Pressure Detected Validity
- e. The following signals shall be transmitted by the EBCM when an EBCM is present; otherwise they are transmitted by the wheel speed sensing module when the EBCM is not present. These signals shall be received and processed by the Powertrain electronics.
- (1) Wheel Rotational Status Left Driven
 - (2) Wheel Rotational Status Right Driven
 - (3) Wheel Rotational Status Left Non Driven
 - (4) Wheel Rotational Status Right Non Driven

4.1.2 Context Diagrams.

4.1.2.1 Powertrain Algorithm.

Not applicable.

4.1.2.2 Platform Algorithm.

Not applicable.

4.1.3 Platform Algorithm Requirements.

The following subsections define the required algorithm content that shall reside in the Platform electronics.

4.1.3.1 Conventional Cruise Control.

The platform module shall be responsible for interpreting cruise mode switch states and communicating them via GMLAN signals to the ECM. Further details can be located in Section 3 Cruise Control Subsystem Requirements. The platform resident diagnostics associated with these switches can be located in Section 4.1.7.2 Platform Resident Diagnostics.

4.1.3.2 Adaptive Cruise Control.

4.1.3.2.1 Automatic Braking Determination.

The EBCM shall be responsible for determining when automatic braking is required to achieve the acceleration requested (**Adaptive Cruise Control Command: Adaptive Cruise Control Acceleration Request**) by the ACC module. Automatic braking shall only be available when ACC is active (**Adaptive Cruise Control Command: Adaptive Cruise Control Active** is "True") or in transition mode (**Adaptive Cruise Control Command: Adaptive Cruise Control Transition Mode Active** is "True"). Powertrain shall communicate two engine torque values to enable the EBCM to comprehend the powertrain contribution to the vehicle deceleration. The two GMLAN signals are **Engine Torque Actual Extended Range** and **Vehicle Deceleration Engine Torque Minimum Extended Range**. Additionally, powertrain shall communicate **Transmission Overall Estimated Torque Ratio**. This signal can be used to convert the engine torque values to axle torque values. The EBCM shall communicate if automatic braking is active via the GMLAN signal **Adaptive Cruise Control Braking Active**.

4.1.3.2.2 Check for PTO Active.

The ACC module shall not engage ACC if the PTO subsystem is active. The PTO subsystem is active if **Power Take Off Active** is "True".

4.1.3.2.3 Limit Requested Acceleration

The ACC module shall monitor and limit the actual vehicle acceleration. The ACC module shall modify the acceleration request going to the ECM as necessary to ensure the actual vehicle acceleration does not exceed

the limits specified in Table 5. Brief excursions, such as with a transmission downshift, may exist until reducing the acceleration request can provide compensation.

Table 5: Limit Requested Acceleration

Vehicle Speed (km/h)	Acceleration Limit (m/s ²)
30	1.8
45	1.8
60	1.7
75	1.55
90	1.4
105	1.25

4.1.3.2.4 Vehicle Speed Processing.

Vehicle speed data may be available in several forms as defined in Section 3. A GMLAN signal **Vehicle Speed Average Driven** sent by the ECM is used for vehicle speed display purposes. The source associated with **Vehicle Speed Average Driven** is defined by GMLAN signal **Vehicle Speed Average Driven Source**. In determining the Driver Selected Speed, if ACC uses a vehicle speed source other than that used to generate the **Vehicle Speed Average Driven** signal, a similar filter rate should be applied as the filter used in determining the Driver Selected Speed to minimize differences to the displayed vehicle speed. Note, if ACC uses a vehicle speed source other than that used for **Vehicle Speed Average Driven**, an offset may exist in the displayed Driver Selected Speed and the vehicle speed displayed via the speedometer under steady state conditions.

4.1.4 Powertrain Algorithm Requirements.

The following subsections define the required algorithm content that shall reside in the Powertrain electronics.

4.1.4.1 Conventional Cruise Control.

4.1.4.1.1 Cruise Switch Moding Diagrams (Figure 2 – 6).

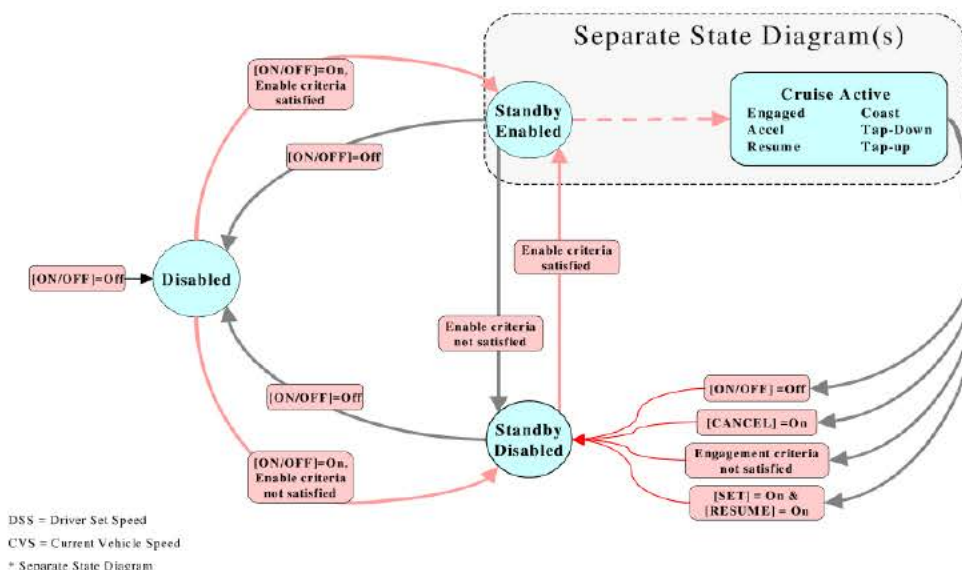

Figure 2: Cruise Control State Diagram (Enabled/Disabled)

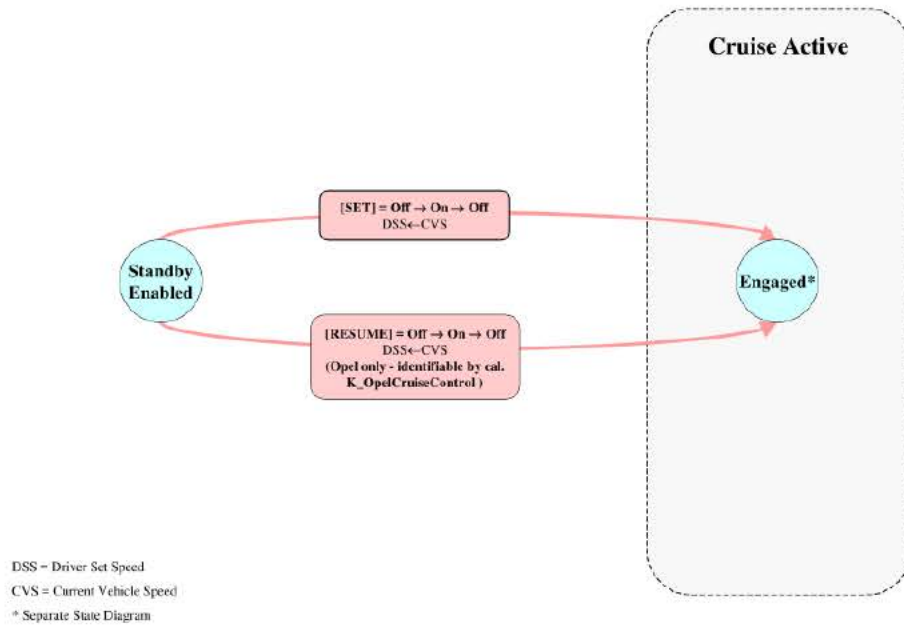

Figure 3: Cruise Control State Diagram (Engagement – with no Driver-set Speed stored)

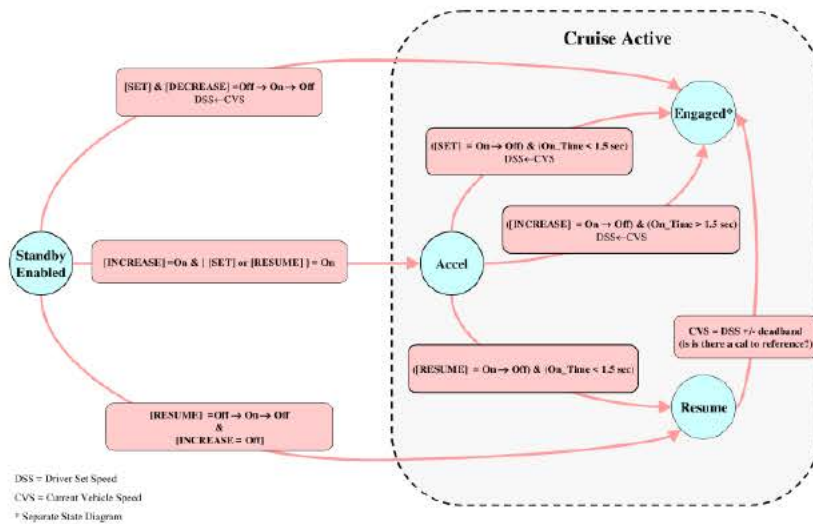

Figure 4: Cruise Control State Diagram (Engagement – with Driver-set Speed stored)

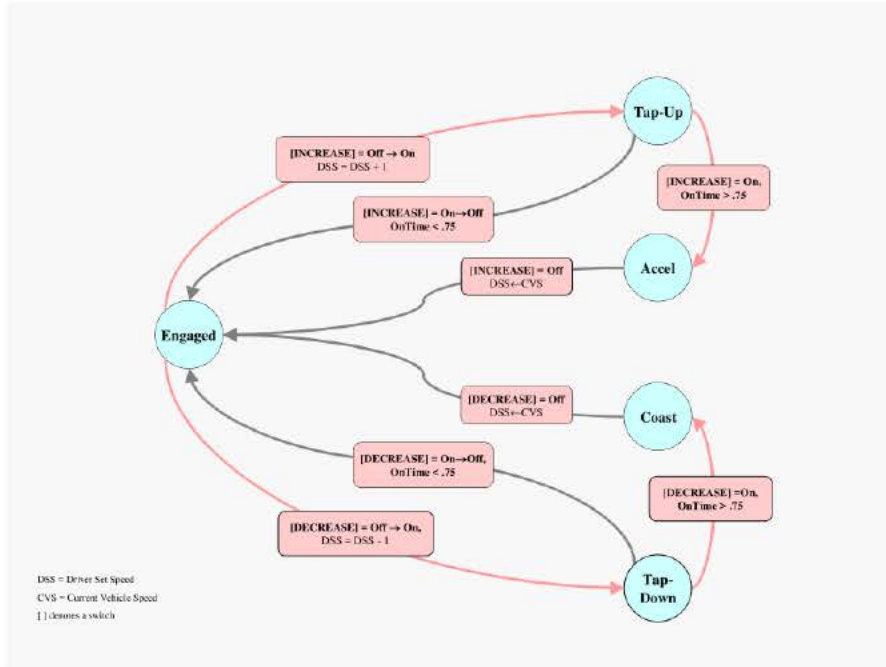

Figure 5: Cruise Control State Diagram Modifying Driver Set Speed

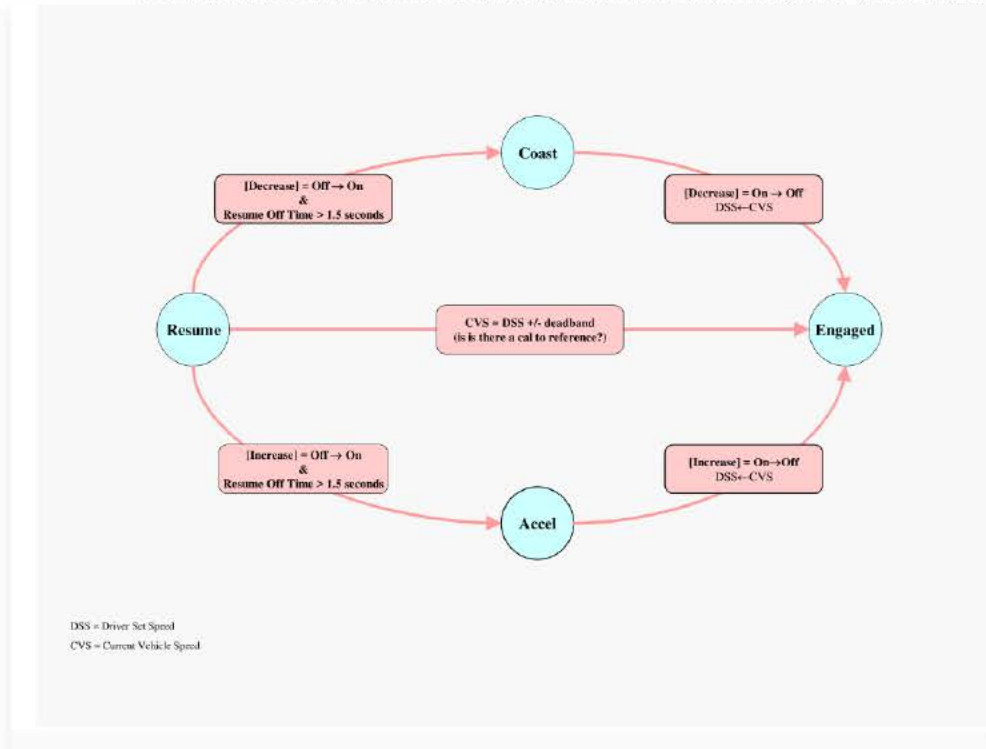

Figure 6: Cruise Control State Diagram

4.1.4.1.1.1 Vehicle Speed Control System Type Verification.

Cruise control will disengage and set a disengagement history code if the value of calibration **K_CruzCruiseSysType** is not "Conventional Cruise Control" or the value broadcast in GMLAN signal **Vehicle Speed Control System Type** is not "Conventional Cruise Control".

4.1.4.1.2 Vehicle Speed Processing.

Vehicle speed data may be available in several forms as defined in Section 3. A GMLAN signal **Vehicle Speed Average Driven** sent by the ECM is used for vehicle speed display purposes. In determining the Driver Set Speed, if cruise control uses a vehicle speed source other than that used to generate the **Vehicle Speed Average Driven** signal, a similar filter rate shall be applied as the filter used in determining the Driver Set Speed. Note, if cruise control uses a vehicle speed source other than that used for **Vehicle Speed Average Driven**, an offset may exist in the displayed **Cruise Control Driver Selected Speed** and the vehicle speed displayed via the speedometer under steady state conditions.

When data is available from all four wheels, cruise control may also reference the Wheel Rotational Status signals to identify wheel slip conditions for cruise control disengagement.

If the calibration **K_MetricTapIncrementEnable** is set to "False", the tap-up/tap-down increment shall be 1.609 km/h (1 mph). If the calibration **K_MetricTapIncrementEnable** is set to "True", the GMLAN signal **Display Measurement System** shall determine the tap-up/tap-down increments. The tap-up/tap-down function shall use increments of 1.609 km/h (1 mph) when the GMLAN signal **Display Measurement System** is transmitted with a value of "English" and whole increments of km/h, typically 1 or 2 km/h when transmitted with a value of "Metric".

4.1.4.2 Adaptive Cruise Control.

4.1.4.2.1 ACC Supervisory Function.

The ECM as part of a rationality check shall monitor several key GMLAN signals and/or inputs. The ECM processing this information redundant to the ACC module enhances the system's robustness. The ECM monitors the information to verify key enable/disengagement criteria before responding to an ACC request for throttle control. If the ECM has not seen critical enable criteria satisfied when ACC becomes active, the ECM shall ignore the ACC request. Additionally if ACC is engaged and the ECM identifies a disengagement criterion satisfied, the ECM shall ignore the ACC commands and initiate an ACC disengagement. The disengagement by the ECM shall be delayed sufficiently to allow the ACC module an opportunity to first recognize the disengagement criterion becoming active and take action.

4.1.4.2.1.1 Parameters Monitored.

The following parameters shall be monitored as part of the supervisory function:

- a. Discrete Inputs:
 - Brake Pedal Apply
- b. GMLAN Signals:
 - Cruise Control Switch Status: On Switch Active
 - Cruise Control Switch Status: Set Switch Active
 - Cruise Control Switch Status: Resume Switch Active
 - Cruise Control Switch Status: Cancel Switch Active
 - Brake Pedal Initial Travel Achieved Status: Brake Pedal Initial Travel Achieved
 - Adaptive Cruise Control Command: Adaptive Cruise Control Active
- c. Internal variables:
 - Vehicle Speed

4.1.4.2.1.2 Supervisory Function Enable Criteria Checked.

The following criteria shall be checked as part of the supervisory function. If the ECM receives an ACC command indicating ACC is active (**Adaptive Cruise Control Command: Adaptive Cruise Control Active** as "True") and the criteria have not been satisfied, the ECM shall ignore the ACC command. If the ACC

© Copyright 2006 General Motors Corporation All Rights Reserved

command continues to indicate ACC active and the enable criteria remain unsatisfied for **K_AccDisengageDelay**, the ECM shall respond by setting **Adaptive Cruise Control Powertrain Inhibit Request** as "Inhibit Adaptive Cruise Control". The ECM shall maintain **Adaptive Cruise Control Powertrain Inhibit Request** as "Inhibit Adaptive Cruise Control" as long as the ACC command continues to indicate ACC active.

- a. No disengagement criteria are satisfied as defined in the following section "Disengagement Criteria Checked".
- b. As long as no disengagement criteria are active, the ECM shall monitor the application and sequencing of various inputs relating to ACC operation. One of two sequences listed below must be satisfied prior to granting an ACC request. If one of these two criteria has been satisfied, it shall continue to be considered satisfied as long as no disengagement criteria is active as defined in section "Disengagement Criteria Checked".
 - 1) **Cruise Control Switch Status: Set Switch Active** has transitioned from "False" to "True" to "False".
 - 2) **Cruise Control Switch Status: Resume Switch Active** has transitioned from "False" to "True" and **Cruise Control Switch Status: On Switch Active** has not been "False" since the criteria in 1) had been satisfied.

Note: The set switch must be used for initial ACC engagement in an ignition cycle or following the Cruise ON/OFF switch being switched from "Off" to "On" in North American applications. This is referred to as the "Set-to-Get" feature. Subsequent engagements of ACC in North American applications can be via application of either the SET or RESUME switch. The ACC supervisory function provides a check on these criteria with the two sequences listed above. Opel applications do not require the "Set-to-Get" feature, where the calibration **K_OpelCruiseControl** defines whether the vehicle is an Opel application.

If for any reason the ECM, based upon this supervisory function, determines ACC should not be operating, the ECM shall ignore the Adaptive Cruise Control Acceleration Request signal. If the disengagement criteria remains active for greater than **K_AccDisengageDelay** and ACC is engaged at the end of this period, the ECM shall initiate a disengagement of ACC and not allow reengagement for the remainder of the ignition cycle by transmitting **Adaptive Cruise Control Powertrain Inhibit Request** as "Inhibit Adaptive Cruise Control".

4.1.4.2.1.3 Supervisory Function Disengagement Criteria Checked.

The following disengagement criteria shall be checked as part of the supervisory function. If the ECM receives an ACC command indicating ACC is active (**Adaptive Cruise Control Command: Adaptive Cruise Control Active** as "True") and any of the following criteria are not satisfied, the ECM shall ignore the ACC command. If the ACC command continues to indicate ACC active and any of the disengagement criteria remain unsatisfied for **K_AccDisengageDelay**, the ECM shall respond by setting **Adaptive Cruise Control Powertrain Inhibit Request** as "Inhibit Adaptive Cruise Control". The ECM shall maintain **Adaptive Cruise Control Powertrain Inhibit Request** as "Inhibit Adaptive Cruise Control" as long as the ACC command continues to indicate ACC active.

- a. Vehicle speed is below a minimum threshold **K_AccLowSpeedDisengage**.
- b. **Cruise Control Switch Status: On Switch Active** is set to "False".
- c. **Brake Pedal Initial Travel Achieved Status: Brake Pedal Initial Travel Achieved** is set to "True".
- d. Discrete input Brake Pedal Apply indicates the brake pedal is applied.
- e. **Cruise Control Switch Status: Cancel Switch Active** is set to "True".

4.1.4.2.2 Additional Inhibit/Disengagement Criteria.

The following criteria shall be monitored by the ECM as part of an inhibit/disengagement determination. Note: these criteria are in addition to the criteria monitored within the supervisory function and diagnostic section. If any of the following criteria are satisfied, the ECM shall cease throttle control relative to ACC operation and set **Adaptive Cruise Control Powertrain Inhibit Request** to "Inhibit Adaptive Cruise Control". The ECM shall

maintain **Adaptive Cruise Control Powertrain Inhibit Request** as "Inhibit Adaptive Cruise Control" while the criteria remain satisfied.

- a. Engine has not been running for a minimum time (typical 5 seconds)
- b. Engine overspeed protection is active
- c. Engine speed is too high (Note, this value is expected to be set below the engine overspeed protection value.)
- d. Failure is identified within ETC subsystem.
- e. ACC Serial data signal time-out
- f. ACC Serial data rolling count/protection value error
- g. Transmission fault
- h. Brake switch fault
- i. Power Take Off (PTO) active
- j. Brake apply serial data signal time-out
- k. Brake apply serial data rolling count/protection value error
- l. Cruise switch failure
- m. Cruise switch rolling count/protection value error
- n. The value of calibration **K_CruzCruiseSysType** is not "Adaptive Cruise Control" or the value broadcast in GMLAN signal **Vehicle Speed Control System Type** is not "Adaptive Cruise Control".

4.1.4.2.3 Conversion of Acceleration.

The command from the ACC module shall be in the form of an acceleration request. The powertrain module may desire to convert the acceleration request to another unit (e.g. axle torque or engine torque). Two calibrations are available to perform this conversion, **K_EffctvTireRollingRadius** and **K_VehicleMassEst** along with the following formula.

$$\text{Acceleration (m/s}^2\text{)} = \frac{\text{AxleTorque(Nm)}}{\text{VehMass(kg)} * [\text{EffectiveTireRollingRadius(mm)/1000}]}$$

4.1.4.2.4 Driver Throttle Override Determination.

Driver Throttle Override Detected shall be set to "True" when the throttle position associated with the accelerator pedal position exceeds the throttle position associated with all of the following: Conventional Cruise Control Throttle Request, Adaptive Cruise Control Acceleration Request or Platform Engine Speed Command: Engine Speed Request (used for Power Take Off and Fast Idle systems). Conventional Cruise Control, ACC and PTO/Fast Idle are mutually exclusive subsystems in that only one of these subsystems can be active at a time; with the inactive subsystems communicating a closed throttle command.

Appropriate hysteresis shall be applied to the threshold to prevent toggling of the signal during steady state conditions. Because ACC automatic braking will be released when **Driver Throttle Override Detected** is "True", the threshold shall be selected such that the "True" state shall only be indicated when the throttle position associated with the pedal is definitely greater than the position associated with either Conventional Cruise Control, ACC or PTO/Fast Idle, whichever system is active. Whenever the determination is ambiguous, **Driver Throttle Override Detected** shall be reported as "False".

4.1.5 Execution/Activation Requirements.

Table 6: Execution/Activation Requirements

Algorithm Section	Platform Nominal Execution Interval	Powertrain Nominal Execution Interval
N/A	N/A	N/A

4.1.6 System State Transition Requirements.

4.1.6.1 Power-up Initialization.

© Copyright 2006 General Motors Corporation All Rights Reserved

Section reserved for future use.

4.1.6.2 Power-Down Initialization.

Section reserved for future use.

4.1.7 Diagnostic Requirements

4.1.7.1 Powertrain Resident Diagnostics

4.1.7.1.1 Cruise Control Mode Switches – Serial Data.

The ECM is responsible for detecting errors associated with the serial communication of the Cruise Control Switch Status. These diagnostics are described in the following sections.

4.1.7.1.1.1 Sliding Window Verification Error Determination (applies to Conventional Cruise only).

The ECM shall perform a "sliding window" check on **Cruise Control Switch Status** as indicated in GMW8772 Section 3 PPEI Serial Data Architecture Requirements. The existence of X Signal Verification Errors (either **Cruise Control Switch Status Alive Rolling Count** error or **Cruise Control Switch Status Protection Value** error) within a window of Y consecutive frames shall constitute a Sliding Window Verification Error. The value of Y shall be between 8 and 16. Typical values for X and Y are X = 4 and Y = 10. Once a sliding window verification error has been determined, conventional cruise control shall disengage, driver selected speed shall be cleared, a DTC shall be stored and engagement shall not be allowed until recovery conditions have been satisfied. Recovery shall consist of the reception of between 20 and 40 consecutive **Cruise Control Switch Status** frames without any signal verification errors present.

4.1.7.1.1.2 Maximum Elapsed Time Since Last Valid Signals.

The ECM shall keep track of the elapsed time since the last valid **Cruise Control Switch Status** signal had been received. A valid **Cruise Control Switch Status** requires no signal verification error and **Cruise Control Switch Status: Switch Data Integrity** received as "Data Valid".

- a. **Conventional Cruise** - If the elapsed time exceeds 500 ms, conventional cruise control shall disengage, driver selected speed shall be cleared and engagement shall not be allowed until recovery conditions have been satisfied.
- b. **Adaptive Cruise Control** - If the elapsed time exceeds 500 ms, the ECM shall cease throttle control immediately relative to ACC operation and delay setting **Adaptive Cruise Control Powertrain Inhibit Request** to "Inhibit Adaptive Cruise Control" sufficiently to allow the ACC module time to recognize the condition and initiate the disengagement. The delay time shall be a calibratable time as defined by K_AccDisengageDelay. At this time the ECM shall default the state of the cruise switches to "False". Defaulting the switches this way will require the next engagement of ACC to be initiated with the SET switch (reference Section 4.1.4.2.1 ACC Supervisory Function). The ECM shall maintain **Adaptive Cruise Control Powertrain Inhibit Request** as "Inhibit Adaptive Cruise Control" until recovery conditions have been satisfied.

Recovery shall consist of the reception of between 20 and 40 consecutive **Cruise Control Switch Status** frames without any signal verification errors present. No DTC shall be set associated with this elapsed time condition.

4.1.7.1.2 Brake Pedal Apply Sensing.

The ECM is responsible for detecting errors associated with the serial communication of brake pedal apply sensing information as well as the Brake Pedal Apply discrete input.

4.1.7.1.2.1 Sliding Window Verification Error Determination.

The ECM shall perform a "sliding window" check on **Brake Pedal Initial Travel Achieved Status** as indicated in GMW8772 Section 3 PPEI Serial Data Architecture Requirements. The existence of X Signal Verification Errors (either **Brake Pedal Position Alive Rolling Count** error or **Brake Pedal Initial Travel Achieved Protection** error) within a window of Y consecutive frames shall constitute a Sliding Window Verification Error. The value of Y shall be between 8 and 16. Typical values for X and Y are X = 4 and Y = 10. Reference Brakes and Traction Control Algorithm Requirements section for more detail. Once a sliding window verification error has been determined, cruise control shall disengage as defined below, a DTC shall be stored and engagement shall not be allowed until recovery conditions have been satisfied. Recovery shall consist of the reception of between 20 and 40 consecutive **Brake Pedal Initial Travel Achieved Status** frames without any signal verification errors present.

- a. **Conventional Cruise:**

Once a sliding window verification error has been determined, conventional cruise control shall disengage immediately and driver selected speed shall be cleared

b. Adaptive Cruise Control:

Once a sliding window verification error has been determined, the ECM shall cease throttle control relative to ACC operation and delay setting **Adaptive Cruise Control Powertrain Inhibit Request** sufficiently to allow the ACC module time to recognize a sliding window verification error and initiate the disengagement. The delay time shall be a calibratable time as defined by **K_AccDisengageDelay**.

4.1.7.1.2.2 Maximum Elapsed Time Since Last Valid Signals.

The ECM shall keep track of the elapsed time since the last valid **Brake Pedal Initial Travel Achieved Status** signal had been received. A valid **Brake Pedal Initial Travel Achieved Status** requires no signal verification error and **Brake Pedal Initial Travel Achieved Status: Brake Pedal Initial Travel Achieved Validity** received as "Valid". If the elapsed time exceeds 500 ms, cruise control shall disengage as defined below and engagement shall not be allowed until recovery conditions have been satisfied. Recovery shall consist of the reception of between 20 and 40 consecutive **Brake Pedal Initial Travel Achieved Status** frames without any signal verification errors present. No DTC shall be set associated with this elapsed time condition.

a. Conventional Cruise:

Once a maximum elapsed time error has been determined, conventional cruise control shall disengage immediately.

b. Adaptive Cruise Control:

Once a maximum elapsed time error has been determined, the ECM shall cease throttle control relative to ACC operation and delay setting **Adaptive Cruise Control Powertrain Inhibit Request** sufficiently to allow the ACC module time to recognize a maximum elapsed time error and initiate the disengagement. The delay time shall be a calibratable time as defined by **K_AccDisengageDelay**.

4.1.7.1.2.3 Brake Pedal Initial Travel Achieved Status is "Invalid".

a. Conventional Cruise:

Conventional cruise control shall disengage immediately when a valid **Brake Pedal Initial Travel Achieved Status: Brake Pedal Initial Travel Achieved Validity** is received as "Invalid". A valid signal requires no signal verification error be present.

b. Adaptive Cruise Control:

If a valid **Brake Pedal Initial Travel Achieved Status: Brake Pedal Initial Travel Achieved Validity** is received as "Invalid", the ECM shall cease throttle control relative to ACC operation and delay setting **Adaptive Cruise Control Powertrain Inhibit Request** sufficiently to allow the ACC module time to recognize the condition and initiate the disengagement. The delay time shall be a calibratable time as defined by **K_AccDisengageDelay**. A valid signal requires no signal verification error be present.

4.1.7.1.2.4 Brake Apply Discrete Failed in "Not Applied" State.

The ECM shall apply a rationality check to assess the functionality of the brake pedal apply discrete input against the GMLAN signal **Brake Pedal Initial Travel Achieved Status** signal. The diagnostics identifies failures of the brake pedal apply discrete input in the "Not Applied" state. The rationality check shall monitor the vehicle speed signals to identify specific vehicle deceleration conditions. The deceleration conditions require the vehicle speed initially be above a calibratable threshold and later drop below a calibratable threshold within a calibratable time period, thereby exceeding a deceleration threshold. A failure is defined when a deceleration exceeds the threshold, the GMLAN signal **Brake Pedal Initial Travel Achieved Status** is in the "True" state and the Brake Pedal Apply discrete has not indicated the "Applied" state. A DTC shall be set if a calibratable number of failures occur and **Powertrain Brake Pedal Discrete Input Status Validity** signal shall be set to "Invalid".

4.1.7.1.2.5 Brake Apply Discrete Failed in "Applied" State.

The ECM shall apply a rationality check to assess the functionality of the brake pedal apply discrete input against the GMLAN signal **Brake Pedal Initial Travel Achieved Status** signal. The diagnostics identifies failures of the brake pedal apply discrete input in the "Applied" state. The rationality check shall monitor the

© Copyright 2006 General Motors Corporation All Rights Reserved

vehicle speed signals to identify specific vehicle acceleration conditions. The acceleration conditions require the vehicle speed initially be below a calibratable threshold and later increase above a calibratable threshold within a calibratable time period, thereby exceeding an acceleration threshold. A failure is defined when an acceleration exceeds the threshold, the GMLAN signal **Brake Pedal Initial Travel Achieved Status** is in the "False" state and the Brake Pedal Apply discrete has not indicated the "Not Applied" state. A DTC shall be set if a calibratable number of failures occur and **Powertrain Brake Pedal Discrete Input Status Validity** signal shall be set to "Invalid".

4.1.7.1.3 Adaptive Cruise Control Command (applies to ACC only).

For adaptive cruise control, the ECM is responsible for detecting errors associated with the serial communication of the **Adaptive Cruise Control Command**. These diagnostics are described in the following sections.

4.1.7.1.3.1 Sliding Window Verification Error Determination.

The ECM shall perform a "sliding window" check on **Adaptive Cruise Control Command** as indicated in GMW8772 Section 3 PPEI Serial Data Architecture Requirements. The existence of X Signal Verification Errors (either **Adaptive Cruise Control Command Alive Rolling Count** error or **Adaptive Cruise Control Command Protection** error) within a window of Y consecutive frames shall constitute a Sliding Window Verification Error. The value of Y shall be between 8 and 16. Typical values for X and Y are X = 4 and Y = 10. Once a sliding window verification error has been determined, the ECM shall store a DTC, stop ACC throttle control and disengage ACC if active by setting **Adaptive Cruise Control Powertrain Inhibit Request** to "Inhibit Adaptive Cruise Control" until recovery conditions have been satisfied. Recovery shall consist of the reception of between 20 and 40 consecutive **Adaptive Cruise Control Command** frames without any signal verification errors present.

4.1.7.1.3.2 Maximum Elapsed Time Since Last Valid Signals.

The ECM shall keep track of the elapsed time since the last valid **Adaptive Cruise Control Command** signal had been received. A valid **Adaptive Cruise Control Command** requires no signal verification error present. If the elapsed time exceeds 500 ms, the ECM shall stop ACC throttle control and disengage ACC if active by setting **Adaptive Cruise Control Powertrain Inhibit Request** to "Inhibit Adaptive Cruise Control" until recovery conditions have been satisfied. Recovery shall consist of the reception of between 20 and 40 consecutive **Adaptive Cruise Control Command** frames without any signal verification errors present. No DTC shall be set associated with this elapsed time condition.

4.1.7.1.4 Vehicle Speed Sensing.

The diagnostics associated with vehicle speed are defined by the Vehicle Speed and Rough Road Sensing subsystem. Both Conventional Cruise Control and Adaptive Cruise Control shall disengage if a failure exists associated with the vehicle speed signals.

4.1.7.2 Platform Resident Diagnostics

4.1.7.2.1 Cruise Control Mode Switches.

The cruise mode switches interface directly to a platform module (most likely Gateway). The platform module processes the cruise mode switch inputs and relays the state of the switches to the ECM. The platform module is responsible for detecting failures and setting the appropriate diagnostic codes as defined in the following sections. The ECM shall diagnose failures associated with the serial communication of the switch states.

4.1.7.2.1.1 Diagnostics Provided by Platform Module.

The following Diagnostic Trouble Codes (DTCs) are to be maintained by the platform module (e.g. Gateway module) processing the cruise switches.

4.1.7.2.1.2 Analog Cruise Switch Diagnostics.

The following diagnostics only apply to an architecture where the cruise switches are combined via a resistive ladder to provide a single analog input voltage to the processing module.

4.1.7.2.1.2.1 Analog Switch Supply Voltage Range.

If the range of the analog switch supply voltage compromises the ability to properly interpret the state of the cruise switches, the Gateway shall communicate this to the ECM by setting GMLAN signal **Cruise Control Switch Status: Switch Data Integrity** = "Data Invalid". Typical values are analog switch supply voltage being

below 10 volts or above 16 volts. The cruise control system can recover from this condition once the analog switch supply voltage returns to a valid range and there are no other disengagement criteria present.

4.1.7.2.1.2.2 Analog Cruise Switch Voltage Range Invalid.

There are two methods by which this code can be set as defined below.

Each switch has a dedicated (valid) voltage range within the total analog voltage range. The various valid switch voltage ranges are separated by deadbands. Whenever the input voltage resides continuously in an invalid range for greater than a calibratable time period (e.g. 1 to 2.5 seconds) a DTC code shall be set. Once the code is set, the code shall be latched for the remainder of the ignition cycle.

Additionally, an invalid range (short to ignition) shall be provided at the high end of the total analog voltage range to detect a short to ignition voltage. Whenever the input voltage resides continuously in this invalid range (short to ignition) for greater than a calibratable time period (e.g. 1 to 2.5 seconds) a DTC code shall be set. Once the code is set, the code shall be latched for the remainder of the ignition cycle.

When this DTC is set, **Cruise Control Switch Status: Switch Data Integrity** shall be set to "Failure Detected". When the voltage resides in an invalid range but the DTC is not set, **Cruise Control Switch Status: Switch Data Integrity** shall be set to "Data Invalid".

4.1.7.2.1.3 RESUME Switch Applied Too Long.

If the RESUME switch is continuously applied for greater than a calibratable time (e.g. 60 seconds), a DTC code shall be set. Once the code is set, the code shall be latched for the remainder of the ignition cycle. When this DTC is set, **Cruise Control Switch Status: Switch Data Integrity** shall be set to "Failure Detected".

4.1.7.2.1.4 SET Switch Applied Too Long.

If the SET switch is continuously applied for greater than a calibratable time (e.g. 60 seconds), a DTC code shall be set. Once the code is set, the code shall be latched for the remainder of the ignition cycle. When this DTC is set, **Cruise Control Switch Status: Switch Data Integrity** shall be set to "Failure Detected".

4.1.7.2.2 Brake Pedal Apply Sensing.

The diagnostics associated with brake pedal apply sensing is defined by GMW8773 Section 4 PPEI Brakes and Traction Control Algorithm Requirements. When any failure is present associated with the brake pedal apply sensing, **Brake Pedal Initial Travel Achieved Status: Brake Pedal Initial Travel Achieved Validity** shall be set to "Invalid".

4.1.7.2.3 Driver Throttle Override Detected – Serial Data.

4.1.7.2.3.1 Sliding Window Verification Error Determination.

The EBCM shall perform a "sliding window" check on **Driver Throttle Override Detected** as indicated in GMW8772 Section 3 PPEI Serial Data Architecture Requirements. The existence of X Signal Verification Errors (either **Driver Throttle Override Detection Alive Rolling Count** error or **Driver Throttle Override Detected Protection Value** error) within a window of Y consecutive frames shall constitute a Sliding Window Verification Error. The value of Y shall be between 8 and 16. Typical values for X and Y are X = 4 and Y = 10. Once a sliding window verification error has been determined, the EBCM shall store a DTC and initiate ACC disengagement via communication with the ACC module until recovery conditions have been satisfied. Recovery shall consist of the reception of between 20 and 40 consecutive **Driver Throttle Override Detected** frames without any signal verification errors present.

4.1.8 Off-Vehicle Communications.

The following data shall be made available through PIDs:

More detailed information regarding specific PID definitions can be referenced in the corporate PID database.

4.1.8.1 Powertrain – ECM.

The following PIDs are applicable to conventional cruise control only.

- a. Cruise Control Disengage History Info 1
- b. Cruise Control Disengage History Info 2
- c. Cruise Control Disengage History Info 3
- d. Cruise Control Disengage History Info 4

- e. Cruise Control Disengage History Info 5
- f. Cruise Control Disengage History Info 6
- g. Cruise Control Disengage History Info 7
- h. Cruise Control Disengage History Info 8
- i. Cruise Control Status

4.1.8.2 Platform – Gateway Module.

Cruise Mode Switch States

4.1.9 Data Dictionary.

4.1.9.1 Calibrations.

All calibrations are Platform-owned unless otherwise noted.

4.1.9.1.1 Powertrain Calibrations.

K_EffctvTireRollingRadius =

Defines the Effective Tire Rolling Radius. The calibration can be derived from data from the Tire and Wheel Group. The calibration is defined as the deflected tire radius for the driven wheel, at 85% loading, vehicle placard tire inflation pressure and ½ tread depth. On applications with multiple tires available, the value should be based upon the average values calculated for the available tires.

Range: 250 - 425 mm

Resolution: 1.0 mm

Typical Value: 315 mm

Emissions Related: No

Cal value owner: Platform

Location: Powertrain

K_VehicleCurbMass =

Mass of base vehicle (referred to as *VehMass* in the algorithm) w/o driver and w/full fuel tank. This calibration is used along with other data to develop **K_VehicleMassEst** for use in the cruise algorithm.

Range: 1 - 5000 kg

Resolution: 1.0 kg

Typical Value: 1500 kg

Emissions Related: No

Cal value owner: Platform

Location: Powertrain

K_VehicleMassEst =

Mass of base vehicle w/ driver and full fuel tank however no passengers or trailer [Base curb mass + single occupant mass (68.0 kg)]. This calibration is used to translate between vehicle acceleration and axle torque values.

Range: 1 - 5000 kg

Resolution: 1.0 kg

Typical Value: 1500 kg

Emissions Related: No

Cal value owner: Platform

Location: Powertrain

K_AccDisengageDelay =

The time the ECM should delay before disengaging ACC for a criterion that is also monitored by the ACC module. This allows the ACC to first initiate disengagements under normal operation providing a consistent disengagement history. If a disengagement criterion is satisfied within the ECM that is not monitored by the ACC module, the ECM is to disengage immediately and not apply the delay. The delay begins when a criterion has first been satisfied. Note the ECM shall cease throttle control during the delay period.

Range: 0-1000 ms
Resolution: 1.0 ms
Typical Value: 500 ms
Emissions Related: No
Cal value owner: Platform
Location: Powertrain

K_MetricTapIncrementEnable =

Defines whether the tap-up/tap-down increment for conventional cruise control is dependent on the content of **Display Measurement System**. This calibration can be set to "True" or "False" with the following meaning:

True = Tap increment of 1 or 2 km/h is used when **Display Measurement System** is "Metric" and tap increment of 1.609 km/h (1.0 mph) is used when **Display Measurement System** is "English".

False = Tap increment of 1.609 km/h (1.0 mph) is used regardless of content of **Display Measurement System**.

Range: n/a
Resolution: n/a
Typical Value: True/False
Emissions Related: No
Cal value owner: Platform
Location: Powertrain

Note: There are a number of issues that the platform may consider when deciding how to set this calibration and these include whether the vehicle is being exported, the likelihood that metric displays will be chosen by the driver, whether **Cruise Control Driver Selected Speed** is being displayed to the driver, whether vehicle speed is being displayed digitally, whether the vehicle has a Head-Up display, whether the change can be made to all of the platform's powertrains at the same time and whether the Owner's Manual text can reflect the chosen functionality.

K_OpelCruiseControl =

Defines whether the vehicle is an Opel application. This calibration allows the cruise control system to accommodate unique Opel system behavior such as not using the "Set-to-Get" function. "Set-to-Get" requires the first cruise engagement in an ignition cycle be via application of the "SET switch".

Range: n/a
Resolution: n/a
Typical Value: True/False
Emissions Related: No
Cal value owner: Platform
Location: Powertrain

K_AccLowSpeedDisengage =

When the vehicle speed drops below this threshold, the ECM shall cease responding to any ACC acceleration request and send **Adaptive Cruise Control Powertrain Inhibit Request** as "Inhibit Adaptive Cruise Control". Reference Section 4.1.4.2.1 ACC Supervisory Function.

Range: 0-40 kph
Resolution: 1.0 kph
Typical Value: 25 kph
Emissions Related: No
Cal value owner: Platform
Location: Powertrain

K_CruzCruiseSysType=

This calibration will add protection against the cruise control system type changing "on the fly" incorrectly via service procedure/reflash, etc. The calibration in the ECM will be compared against the information contained in the serial data signal Vehicle Speed Control System Type that is received from platform. If these are not the same, cruise control will be disengaged/inhibited (adaptive cruise control or conventional cruise control). The calibration has three possible values:

Range: None, Conventional Cruise Control and Adaptive Cruise Control.

Resolution: N/A

Typical Value: N/A

Emissions Related: No

Cal value owner: Platform

Location: Powertrain

4.1.9.1.2 Platform Calibrations.

Section reserved for future use.

4.1.9.2 Variables.

Section reserved for future use.

5 Provisions for Shipping

Not Applicable.

6 Notes**6.1 Glossary**

None.

6.2 Acronyms, Abbreviations, and Symbols.

See GMW8762 Appendix Section A.3

7 Additional Paragraphs

7.1 All materials supplied to this specification must comply with the requirements of GMW3001, **Rules and Regulations for Materials Specifications.**

7.2 All materials supplied to this specification must comply with the requirements of GMW3059, **Restricted and Reportable Substances for Parts.**

8 Coding System

This specification shall be referenced in other documents, drawings, VTS, CTS, etc. as follows:

GMW8769

9 Release and Revisions

9.1 Release. This general specification originated in June 2003; approved by The Global PPEI Core Team in December 2003 and initially published in February 2004 for the Global PPEI Version 3.4.

9.2 Revisions.

Rev	Approval Date	Description (Organization)
A	Aug 2004	Global PPEI Version 3.5 Release.
B	Jul 2005	Global PPEI Version 3.6 Release.
C	Mar 2006	Global PPEI Version 3.7 Release.

Appendix A

The following are approved Change Request(s) (CRs) for the Global PPEI Version 3.7 Release that impacted the GMW8769 Cruise Control Subsystem:

Sections Changed	Description Of Changes	Rationale/Authorization
	No changes were made to GMW8769 Cruise Control Subsystem Standard for the Global PPEI Version 3.7 Release.	

Deviations

None.