



Installation Instructions SUPERCHARGER

For the Mazda Miata 1.8L Models '94-97
999-100 w/ power steering, with AC
999-105 w/ power steering, without AC
999-110 w/out power steering, without AC
999-130 w/out power steering, with AC

440 Rutherford St. P.O. Box 847 Goleta, CA 93117
1-888-888-4079 • FAX 805-692-2525 • www.jacksonracing.com

INSTALLATION TIME: LESS THAN 4 HOURS FOR EXPERIENCED MECHANICS, AROUND 5 TO 8 HOURS FOR "OCCASIONAL" MECHANICS. TOOLS REQUIRED: 3/8" Drive Socket set w/ 17-mm, 14-mm, 13-mm, 12-mm, 10-mm, & 8-mm sockets; Deep sockets (14-mm or 9/16", 10-mm); Phillips and Standard screwdriver; 10-mm, 12-mm, and 17-mm open end wrench; 5-mm Allen wrench with a 3/8" drive; paper clip; a box to store your OLD PARTS in. Loctite 242 thread locking compound is recommended. A 1/4" drive socket set will be useful with some of the tight working areas. A timing light will be needed to set the ignition timing.

A NOTE ON ADDING A SUPERCHARGER TO YOUR MIATA

This kit has been carefully designed with attention to every detail utilizing over 1000 hours of engineering and testing. Each component of this kit has been carefully designed to match the quality of the automobile you purchased from Mazda. The only added maintenance item for your Miata will be an occasional belt tension check for the supercharger drive. As for your engine's life, a Miata engine in good condition will see little reduction in useful life with the addition of this kit. However, it is your responsibility to insure that your

engine is in tiptop shape before you install this kit. Putting boost on a tired engine will lead to catastrophe. If your car has less than 80,000 miles on it and has had the oil changed regularly (every 3000 miles or so), you should have no trouble. If in doubt, check your engine's compression. You should have at least 135psi of compression in each cylinder with no more than a 10% variance between any two cylinders or with a 10% increase in any cylinder after a tablespoon of oil is poured in. Your cooling system should be up to par (50/50 ratio of water to new coolant). Basically, if you have a good engine, it will be very happy with this supercharger, as will you.

BEFORE INSTALLING THIS KIT:

Drive your fuel tank empty and refill with 92-octane major brand gasoline. If you can only find 91-Octane, see step #3 under "Adjustments" at the end of these instructions. Change your oil and filter. Use synthetic oil if possible (Mobil 1 or similar, see notes at end of instructions).

Change your spark plugs if they've more than 10,000 miles on them. We suggest a set of slightly cooler plugs (Moss # 971-050 or for desert conditions Moss # 971-075 or equivalent) to prevent detonation. Gap these plugs at 0.038 inches. Use anti-seize compound on the threads.

Supercharger Installation Instructions

Change your fuel filter if it has more than 20,000 miles on it. This is critical.

1.0 DISASSEMBLY

1.1 Disconnect your Miata's battery, making sure that you know your radio secret code if you have programmed it with such (if you haven't programmed it, don't worry, it won't lock up).

1.2 Release the Air mass sensor harness 5-pin connector by pressing the locking tab on its clip. Remove the stock Air mass sensor from the air box by removing the two 10mm headed retaining bolts and then remove the Air Temperature sensor with its rubber mounting grommet from the Air filter box. And finally remove the air filter assembly complete with intake snorkel; these parts will not be reused. Move the Air mass sensor to a safe place on a worktable.

1.3 Remove the molded rubber elbow and hard plastic tube that lead from the throttle body to the Air mass sensor. If you have cruise control, you will also have to remove the vacuum line from the intake manifold nipple and from the points where it attaches to the hard plastic intake tube. Remove the cruise control vacuum line from the cruise actuator as well and save it for use in step #4.4 below.

1.4 Remove the chrome crankcase vent pipe that is attached to the front of the cam cover and the rubber hose that leads into the cam cover (see figure 1.4). These can be stored away. However, find the small restrictor inside the rubber hose that ran from the chrome tubing to the Mazda plastic crossover/intake tube. If you do not have a restrictor in your hose there is one supplied in the hose bag. It can be felt as a lump in the straight section of the hose near the chrome tube end. Persuade it out by gently clamping the hose with a pair of

Figure 1.4

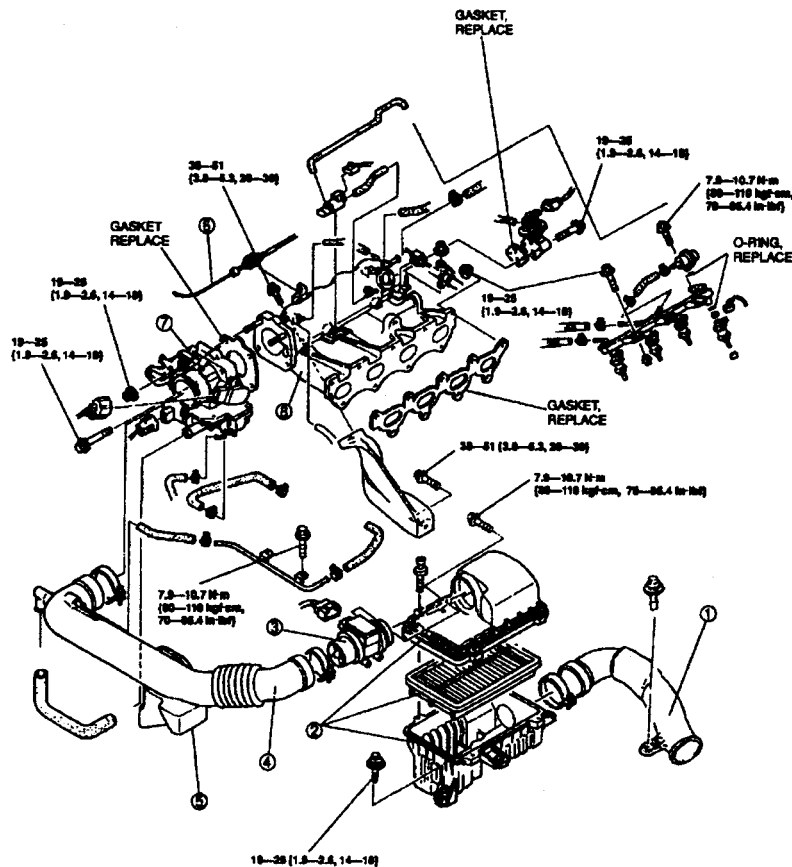

Supercharger Installation Instructions

pliers just behind the lump. Save the restrictor for step #7.8. Re-install the chrome bolts that held the tubing in place. Store the chrome tube and Mazda hoses.

1.5. You can do this entire procedure without losing too much coolant; there is no need to drain your cooling system. In the upcoming step you will be removing the throttle body and Idle Control Solenoid (ICS) valve. If you remove the small coolant hoses that run to the ICS valve (which is mounted under your throttle), you can drain the excess coolant into a coffee can or such. Rest the can on the steering rack down in front of the engine and aim the hoses into the can as they drain. Once the flow stops, you can remove the throttle body without making a mess.

2.0 THROTTLE BODY

2.1 Remove the throttle body (see Figure 1.4) By releasing the two electrical connectors (one has a spring wire, one has a plastic lever clip), the two small coolant hoses on either side of the lower Idle Control System (ICS) valve, and the four bolts.

TIP: THE SPRING HOSE CLAMPS FROM MAZDA ARE BEST REMOVED BY APPROACHING FROM THE SIDE WITH NEEDLE NOSE PLIERS. GRASP ALL THREE TAGS AT ONCE AND COMPRESS THEM TOGETHER. THIS IS EASIER TO DO WITH THE THROTTLE BODY ALREADY LOOSE FROM THE INTAKE MANIFOLD.

Plug the coolant hoses with a screwdriver, golf tee, or pencil to prevent the leakage of coolant (OR - keep the hose ends above the radiator cap level to prevent leakage). Release the throttle cable from the throttle shaft spool. Release the Throttle Position Switch harness by lifting the small wire clip that runs around the rectangular base of the connector. If the throttle body gasket tears as you remove it (even though it is made of metal, it can tear), you will need to clean off the old gasket from

both surfaces, the throttle body and the intake manifold. Carefully use a knife or the back-side of a hacksaw blade to scrape the mounting surfaces clean.

DON'T SCRATCH OR MARK THE MOUNTING SURFACES IN ANY WAY.

2.2 Moving to a worktable, remove the idle air control (ICS) valve from the bottom of the throttle body by removing the four Phillips head screws. Use a good quality screwdriver and be careful not to strip the Phillips head screw. If you cannot loosen a screw with the screwdriver, use a small set of pliers from the side. Carefully separate the two units making sure not to tear the rubber gland gasket. The rubber gland gasket will want to stay with the Mazda throttle body – carefully pick it out with a flat blade screwdriver and save it for the next step. Take the Dummy Throttle body from your supercharger kit and install the Mazda Idle Air Control Valve (ICS) on the bottom, rotating the ICS valve 180° so that the electrical connector now points to the rear of the engine. Use the Mazda gasket or 1104 adhesive provided.

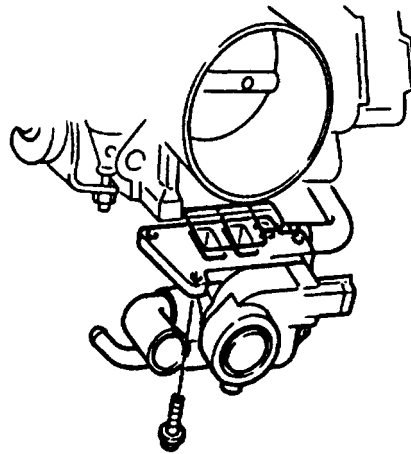

Figure 2.2

2.4 Install the Dummy Throttle Body and ICS valve assembly back onto the intake manifold in the same position as the standard Mazda throttle body on the intake manifold. If the old

Supercharger Installation Instructions

gasket was not salvaged then use a thin film of the sealant provided. Reconnect the coolant hoses to the idle control valve as you found them.

2.5 Reconnect the idle control valve electrical connector.

2.6 Take the Throttle Position Switch (TPS) extension harness from your kit and use it to add the required length to the TPS harness. We have provided the four conductor sheathed wire for this purpose. Use the eight heat-shrink butt connectors to attach the wire ends to each other. First, strip back the electrical tape cover off of the TPS wiring harness. At a spot about 3 inches back from the TPS connector, cut all four wires, then move to the other end of the extension wire. Carefully match the colors so that the correct wires are again joined. Using the butt connectors, again attach the extension wires to the TPS connector wires, crimping the connectors only after you have once again confirmed that all four wires are correctly wired. The heat shrink covers on the butt connectors should be heated to 750° F to shrink gun, a hair dryer can do the trick. If your hairdryer doesn't make enough heat, try covering it's air intake while it is blowing. This will cause a momentary increase in the heat output and should work. If you do this for more than a few seconds, the temperature switch in the hair dryer will open and cut the dryer off. It will reset itself once the dryer cools off- no damage will have occurred. Because there are fuel hoses under the hood, the old trick of using a butane lighter or a lit match is not recommended. When finished heat shrinking the covers, wrap both ends of the extension harness with electrical tape covering the butt connectors from sight and moisture.

2.7 Locate the ICS blanking plate and take it over to your Mazda throttle. A thin layer of sealant will go between the blanking plate and

the Mazda throttle body. Install this blanking plate onto your Mazda throttle body using the four Phillips head screws supplied in the kit.

3.0 BELT DRIVES

3.1 NOTE: CARS WITH POWER STEERING:

You will be re-arranging your power steering bracket components per figure 3.2. Referring to figure 3.1, remove the slot bracket and pillow block by removing bolts "A", "C", and "D". Take the flat idler pulley bracket from your kit and trial fit it to the assembly per figure 3.2. You will be moving the pillow block and bolt "D" to behind the power steering stamped steel bracket (pillow blocks dome facing upward). This makes room for the flat idler pulley bracket. The upper support for the repositioned long bolt "D" comes from a relocated Mazda slot bracket. It becomes an extension bracket for bolt "D". The slot bracket is attached to the stamped steel power steering bracket using a new bolt/washer/nut assembly supplied in your kit. Make sure to point this bolt with its head nearest the plastic idler pulley and that this bolt goes through the slot. The forward hole of the repositioned slot bracket will not be used. The rearward hole is now used for the relocated "D" bolt, which will be used to tighten your drive belt. Note: The power steering pump must be in its lowest position for this procedure.

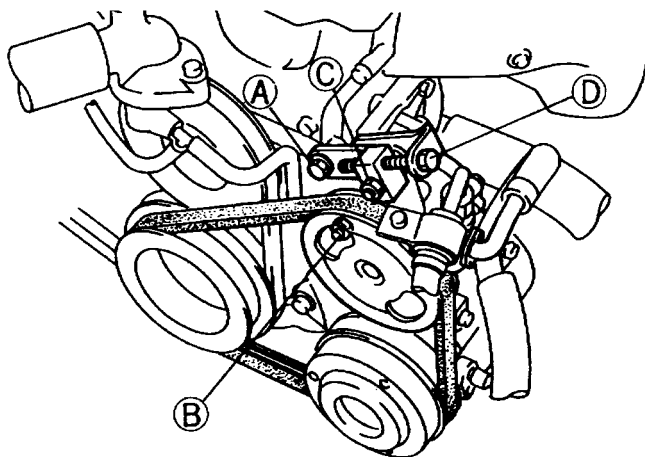
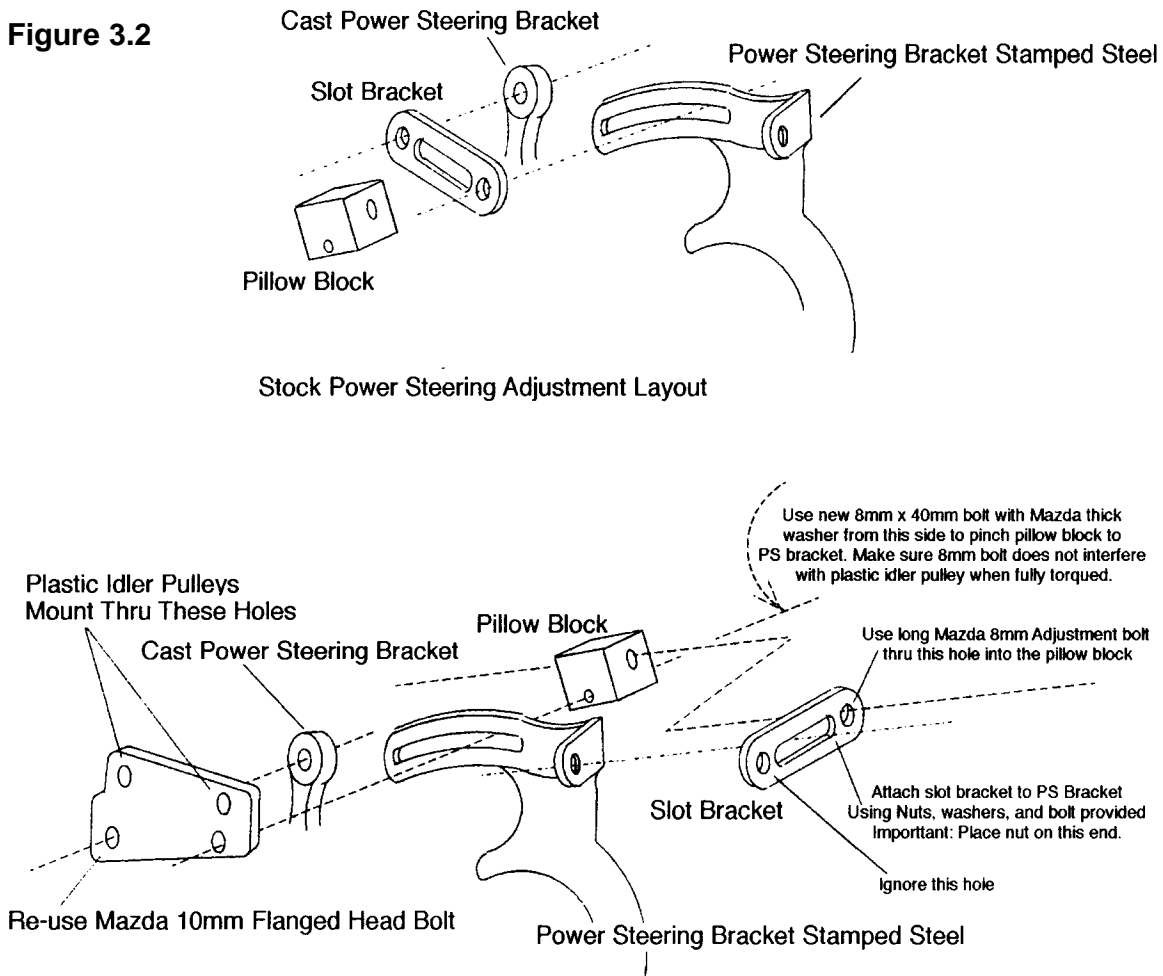

Figure 3.1

Supercharger Installation Instructions

Figure 3.2



Power Steering Adjustment Components for Supercharger Installation

3.2 When you are done with your trial fitting of the flat idler pulley bracket, take this flat bracket to a workbench and install the two plastic idler pulleys using the bolts and nyloc nuts provided. Make sure that the bolts point towards the front of the car. Secure the idler pulleys firmly to the flat bracket. Proceed to install the idler pulley assembly onto the car per the procedure practiced during the trial fitting. The final assembly (minus the pulleys) should look like figure 3.3. **VERY IMPORTANT: MAKE SURE THAT THE DRIVER'S SIDE IDLER PULLEY IS FREE TO SPIN. THE PINCH BOLT THAT YOU INSTALL THROUGH THE PILLOW BLOCK FROM THE**

REAR CAN INTERFERE WITH THE BACK-SIDE OF THE IDLER IF INSTALLED INCORRECTLY (i.e. leaving out the thick washer under the bolts head). TEST THE ASSEMBLY BY TIGHTENING THE PINCH BOLT FULLY AND SPINNING THE IDLER PULLEY. USE ADDITIONAL WASHER'S UNDER THE PINCH BOLTS HEAD IF NECESSARY. VERY IMPORTANT: Check the clearance (Figure 3.2) between the small coolant hose that runs from the base of the thermostat housing and the passenger side plastic idler pulley (see figure 8.1). If the clearance is less than 1/2 inch between the hose and the pulley, trim three quarters of an inch of length off of

Supercharger Installation Instructions

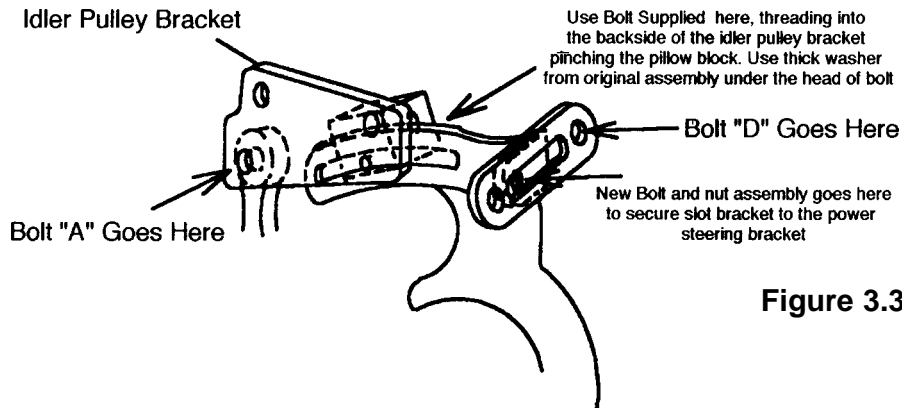

Figure 3.3

**Final Component Assembly For Supercharger Installation.
Pulleys Removed for Clarity**

the thermostat end of the small hose. Reinstall the hose, reusing the spring clamp. By removing a small piece of the hose end, the hose will be pulled away from the idler pulley, avoiding any damage during operation. This is a critical area for attention since a hose failure could cause severe engine damage. Not all cars need this modification.

3.4 POWER STEERING CARS:

Spin the power steering pump pulley until the nut on the main pump mounting bolt is visible. Insert a socket wrench (deep 14-mm) here and

hold the rear hex head with a 14-mm box wrench. Remove the (Figure 3.3 & Figure 3.4) nut and the long bolt (item "B" in figure 3.1). The bolt will retract rearward underneath the exhaust manifold.

3.5 Pick the flat steel supercharger bracket from the kit and slip the long power steering pump mounting bolt through then on-slotted end. Reinstall the power steering pump bolt and nut with the flat bracket pinched between the bolt head and the cast power steering pump bracket that is on the engine. When fin-

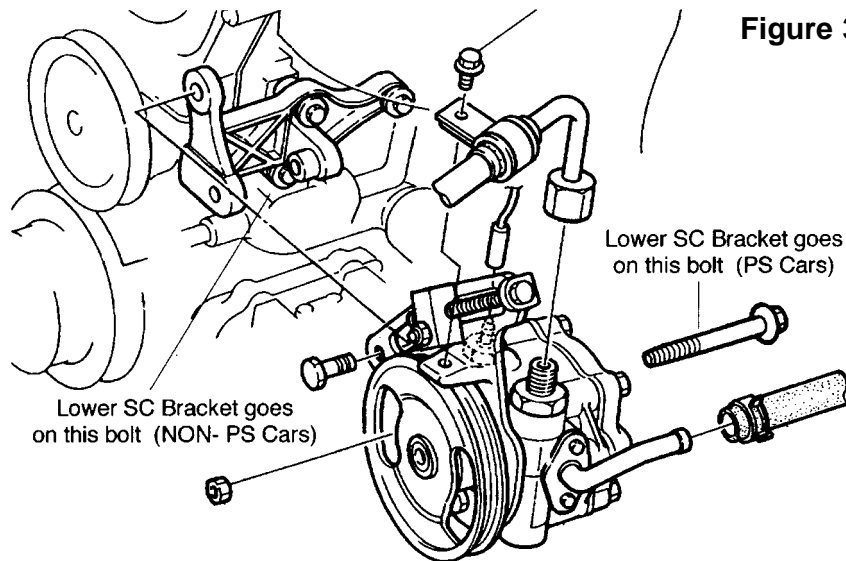

Figure 3.4

Supercharger Installation Instructions

ished, rotate the power steering pump as far down as possible (the pulley will touch the AC compressor pulley if so equipped). This will allow room for the supercharger to be installed and for the belt to slip over the pulleys.

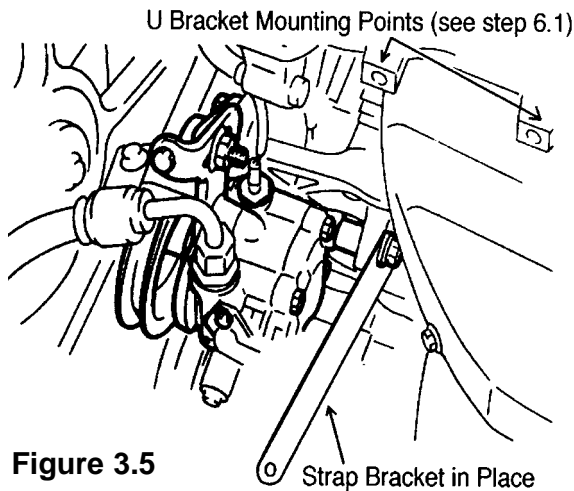

Figure 3.5

3.6 NON POWER STEERING CARS:

Locate your lower bracket assembly from the kit. The end with the small 90 degree bracket mounts to the idler bracket (standard on AC equipped cars) or to new idler bracket (supplied with kit for non-AC, non-PS cars). Use the new, longer 10-mm bolt provided to attach this bracket to the engine (Review figure 3.4 for bolt location).

4.0 FUEL MANAGEMENT

4.1 Install the Idle compensator module on the relay bracket located on the right side wheel arch (see figure 4.1A) mount the module plug base on the unused ear of the relay bracket using the cross head screw, washer and nut provided. Plug the Idle compensator relay into the module plug base with its unused mounting ear towards the engine.

4.2 Electrical connections: Route the blue wire between the fuse box and fender to the windshield wiper motor. Pull the vinyl covering

back on the wiper motor harness exposing the solid blue wire without any stripe. Install the T-tap onto this wire and plug the blue wire from the module into it (see figure 4.1B)

4.3 Install the Black wire from the module around the Evap. canister to the spade connector on the pressure switch located on the dummy throttle body. (See figure 4.1C)

4.4 Route the remaining Black cable containing the Red with Black stripe wires along the firewall and left side of the engine compartment to the Air mass sensor.

4.5 Locate the five-pin Air mass sensor harness and connector end. You will need to splice your idle compensator into the Red/Black wire that occupies the center position of the harness. We have provided heat shrink male/female connectors on either side of the idle compensator for this procedure. Carefully strip away the tape covering the harness at the connector end, exposing at least four inches of the five-wire loom. Cut the red/black center wire approximately two inches from the connector. Strip away at least 1/4inch of insulation from both ends of the cut wire and insert the idle compensator connectors over the stripped ends. Crimp and heat shrink the butt connectors as you did with the TPS harness earlier and cover the spliced area with electrical tape.



Use this Center Wire

Figure 4.1
Air Flow Meter Connector

Supercharger Installation Instructions

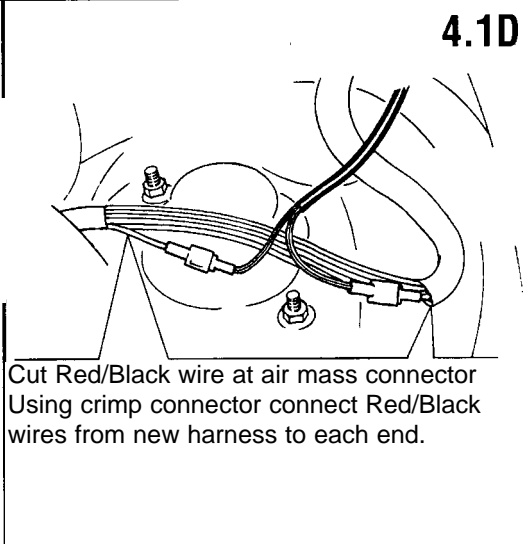
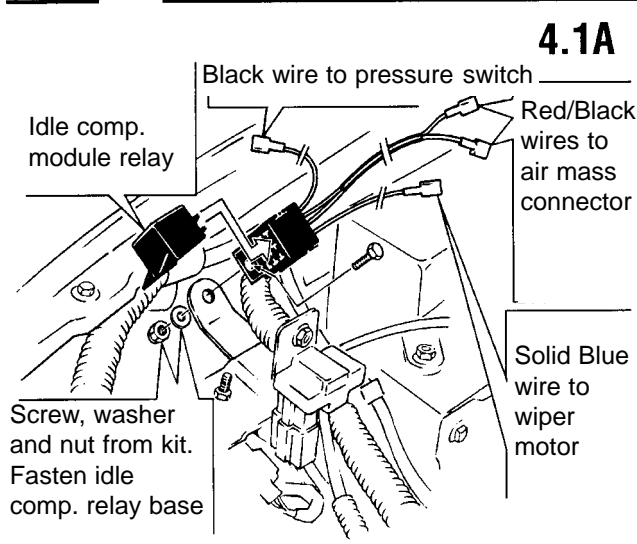
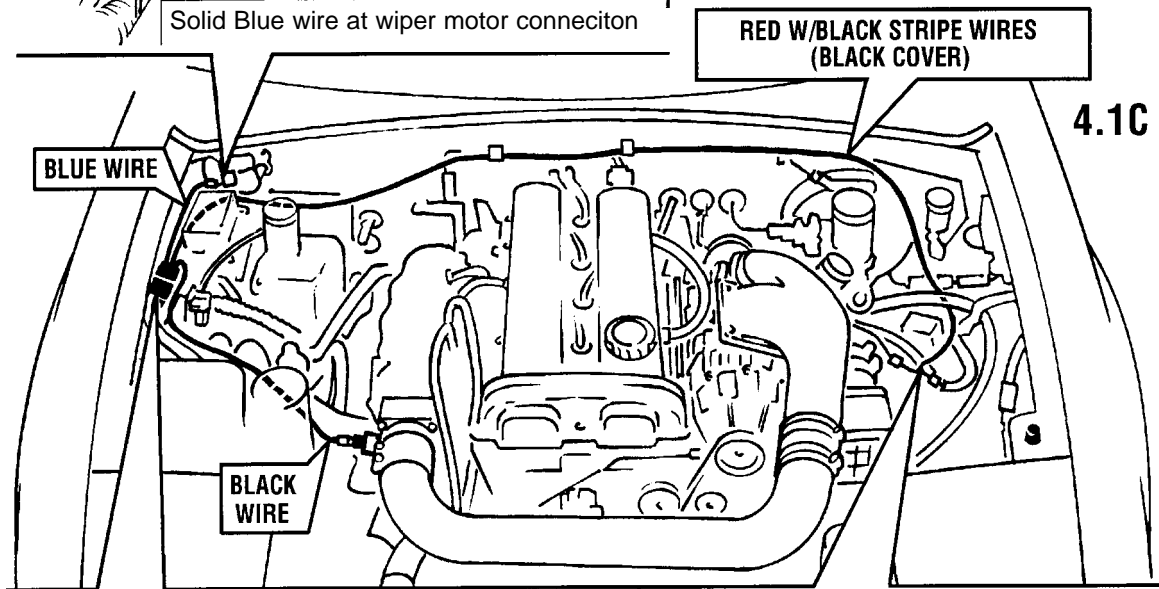
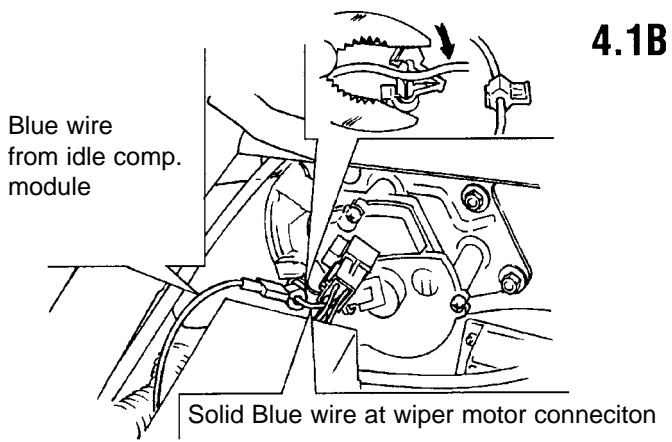

Supercharger Installation Instructions

4.6 Install the Air/Fuel Regulator by first removing the cylindrical black plastic evaporative canister on the right side of the engine compartment from its vertical mounting brace. This is performed by simply sliding the canister upward to remove it. There is a small hole in the brace through which will pass a 6 mm bolt with a 10mm head to fasten the mounting clamp of the Air/Fuel Regulator. Mount the AFR to the brace after connecting the fuel lines. Locate the flexible fuel line attached to the REAR (towards the windshield) of the metal fuel rail that connects the Fuel injectors. Follow this fuel line to the rigid pipe just below the Evap. canister; this pipe will be marked with either a white spot or stripe. Disconnect the flexible fuel line from the rigid pipe and

connect it to the offset brass barb on the bottom of the A/F regulator. Connect a new piece of fuel line to the remaining center brass barb and to the rigid pipe with the white mark, this can be achieved by making a large gentle curve between the two connections. Insure there are no kinks to obstruct fuel flow in any of these lines. Install the vacuum signal hose to the cruise control nipple located just behind the dummy throttle body. If your car has cruise control, use a plastic vacuum "Tee" fitting to tap into this line. Attach the other end of the vacuum signal hose to the nipple on the top portion of the AFR. After making all connections and mounting the AFR Reinstall the Evap. Canister by sliding it back on it's mounting brace.

MOSS AFR

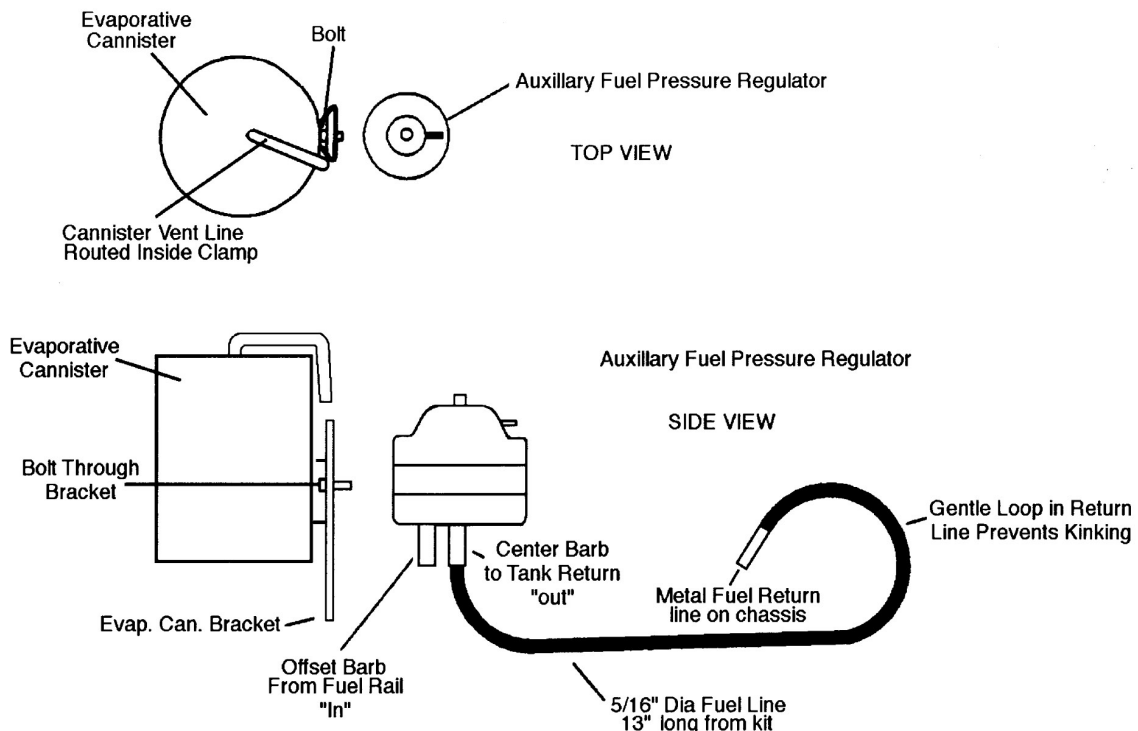

Supercharger Installation Instructions

Figure 5.1

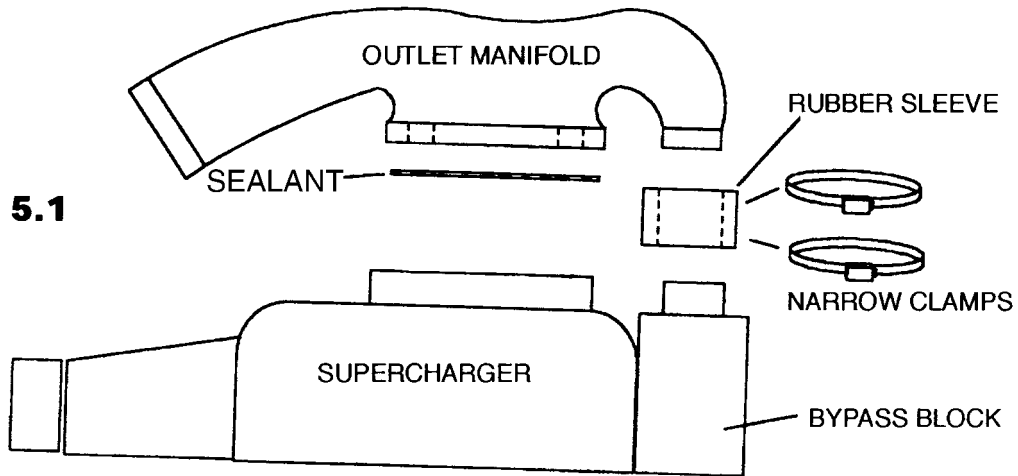

5.0 SUPERCHARGER PREPARATION

5.1 Working on a table, set the supercharger unit in a position easy to work with. Be very careful not to bump the supercharger pulley in any way as it can easily damage the front bearing. Locate the outlet manifold. Check inside the outlet manifold for any debris and clean it out if necessary. Install the outlet manifold as shown in figure 5.1. A thin film of the 1104 sealant provided must be used between the Supercharger and outlet manifold. This can be applied to either surface. Four socket head bolts are provided (use a 6-mm Allen

wrench on the socket head bolts.) These are in Hardware bag 2. On some chargers you might have to remove 2 studs that are in the supercharger flange. Get your Mazda throttle body with the ICS blanking plate as installed in step #2.7 and mount it to the supercharger using the sealant provided and the four bolts (8mm x 40) supplied in the kit.

5.2 Locate your throttle cable bracket that is bolted to your standard intake manifold and remove the throttle cable by loosening the pinch nuts surrounding the cable end on either

Figure 5.2

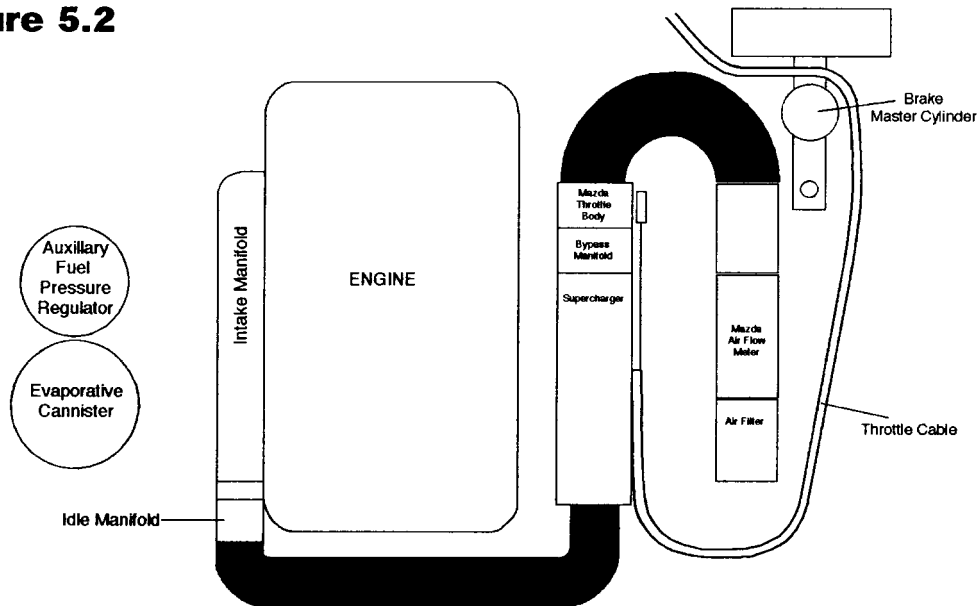

SUPERCHARGER LAYOUT SCHEMATIC

Supercharger Installation Instructions

side of the bracket. Once the nuts are loose, you can pull the cable out of the bracket - the grommet will deform and let you do this. Remove the throttle cable bracket by removing the two 10-mm headed bolts. Unclip the throttle cable from the firewall anchors. Begin re-routing the throttle cable by looping the end behind the brake master cylinder and laying its length along the driver's side fender well.

5.3 Locate the black plastic Roto-mold elbow from your kit. Check inside the elbow for any debris and clean it out if necessary. You will be placing the assembly into the position shown prior to installing the supercharger. Make sure to install the 2.5" to 2.75" reducer hose to the airflow meter end of this elbow prior to setting it in place. This will greatly assist in air flow meter installation. Also, install the 2.5" diameter hump hose to the throttle body end of this elbow. Use the clamps provided to secure the hoses to the elbow.

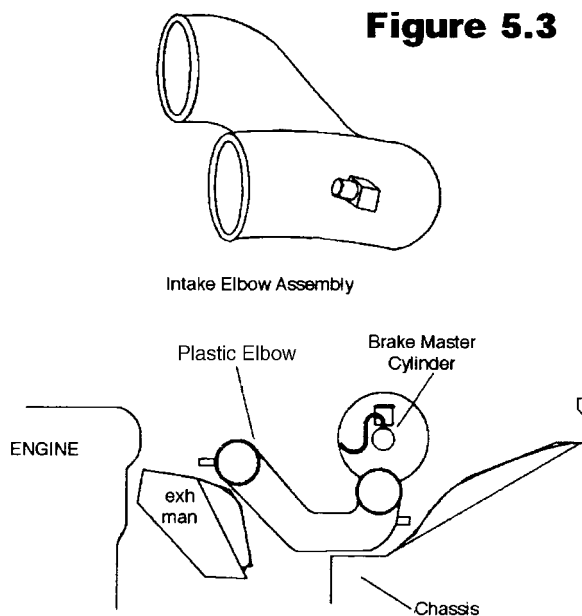

6.0 SUPERCHARGER INSTALLATION

6.1 Remove the engine lift eyelet at the front of the engine, just above the exhaust manifold

by removing the bolt using a 14-mm socket. Install the new flanged headed bolt supplied with your kit into the boss on the side of your cylinder head. Leave at least 1/2" of thread exposed on the bolt. Remove the heat shield from the exhaust manifold. Make sure to spray the small bolts with WD 40 or such and let them soak for a bit to make sure that they do not shear off during removal. Spray your exhaust manifold nuts with WD 40 or equivalent and let soak for ten minutes, re-applying at the five minute point. Remove the nuts from the two top center exhaust manifold studs (#2 and #3, counting from the front). Install the exhaust manifold to supercharger bracket over the two exposed studs. The third hole on the bracket should be offset upwards and away from the engine. Re-install and tighten the two nuts. Remove the counter sunk bolt and nut which hold the main supercharger bracket to the small L-bracket attached to the supercharger unit. Discard the nut; it is for shipping purposes only. Locate the jam nut from the appropriate hardware bag (self locking prevailing torque nut).

Mount Rear Bracket on Exhaust Studs #2 & #3 Reusing Mazda Exhaust Nuts.

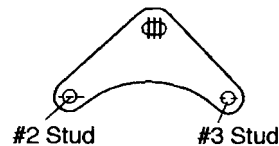

6.2 Bring the supercharger over to the engine. Feed the throttle body end into the hump hose already installed on the black plastic "air flow meter to throttle body elbow" (make sure to slip a fully opened hose clamp over the hose first). Orient the supercharger so that you can slip the forward large "keyhole" in the bracket attached to the supercharger over the bolt head installed in step #6.1. Make sure that the bolt moves up the respective vertical slot and

Supercharger Installation Instructions

seats against the upper edge of the horizontal slot in the bracket. Slide the supercharger towards the firewall as far as it will go. Reinsert the counter sunk bolt removed earlier through the L-bracket, through the main S/C bracket, and through the hole in the exhaust manifold to S/C bracket. The jam nut that goes on this bolt fits tightly between the rear support bracket and the engine's cam cover. Use an open-end wrench and some masking tape to hold the nut to the wrench while you feed it into place. Start the counter-sunk-head bolt with your other hand and run the pair down tight. Tighten down the front pinch bolt using an open-end wrench. If you find that the bracket/supercharger assembly collides with your cam cover vent tube during initial installation, it means you did not leave enough threads exposed on the main mounting bolt installed in step #6.1. Retry it with the bolt further out.

Lower Hole is slotted for adjustment of supercharger mounting angle

Figure 6.1

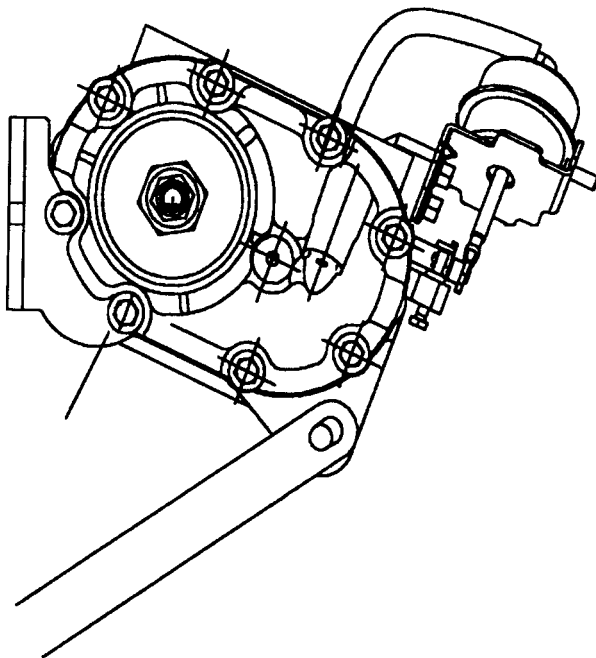

6.4 Swing the flat lower bracket up into place in front of the supercharger boss. Locate the small stamped throttle cable bracket from your kit and thread the new bolt through the throttle cable bracket hole, through the 2" spacer, through the supercharger boss and through the flat steel lower bracket. Secure with the locking nut and bolt supplied. Make sure that the head of the bolt is on the throttle bracket side of the assembly. Leave the power steering pump long bolt and nut finger tight (14-mm heads).

6.6 Route your throttle cable so that it is looped back toward the firewall, routing the cable just behind the driver's side headlamp motor. Install the cable's threaded end into the small bracket attached to the underside of the super-charger. Make certain that the cable/grommet is fully nested within the slot (this may require some muscle – we made it tight so your throttle cable won't ever fall out). Open the throttle by hand and insert the cable end into the throttle spool. Make sure that the cable runs in the center of the groove of the throttle spool. If it does not, adjust the throttle cable bracket left or right until it is centered in the spool's groove. Have an assistant operate the gas pedal multiple times to confirm that the action is free and easy without binding or interference. Make sure that the cable has a bit of "sloppy" slack with the gas pedal released and that full throttle is available when the gas pedal is fully depressed. If it does not "flop" in the idle position, you will have trouble setting your idle speed. Make sure that the cable is run in such a way as to allow for engine movement from side to side. Make very certain that all throttle cable mounting points are secure - this installation area is critical for safe operation of your car. This bracketry has been carefully designed for correct operation. It is your responsibility as the installer to insure that it is bolted together successfully without binding or interference.

Supercharger Installation Instructions

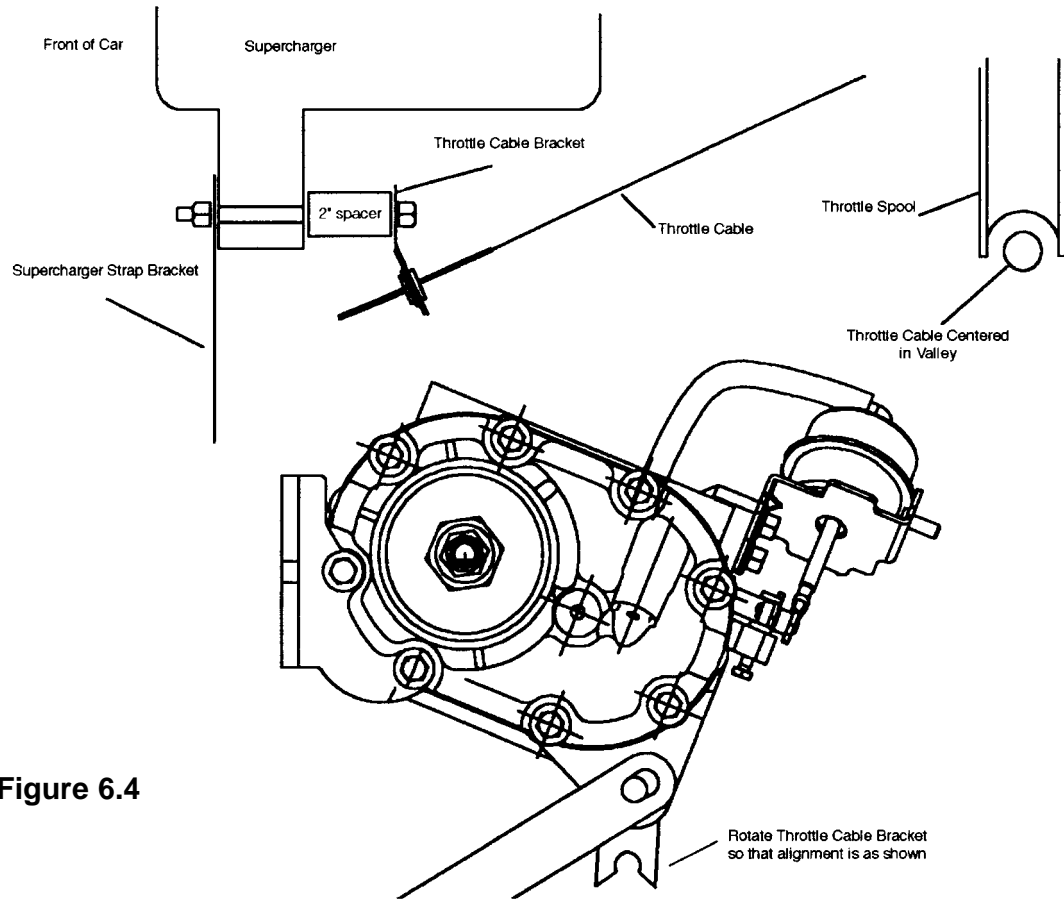

Figure 6.4

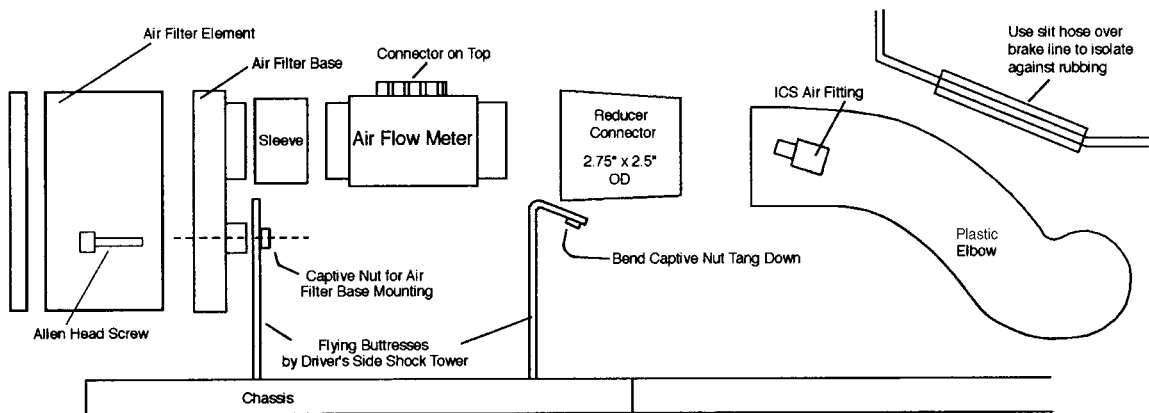

Figure 7.2

Side View of Air Flow Meter Mounting

Supercharger Installation Instructions

7.0 Air Mass Sensor Work

7.1 Locate the new air filter base from your kit and install it to the air flow meter intake port, using the supplied sleeve and clamps.

7.2 Locate the driver's side shock tower support and notice the Mazda air filter box mounting bracket (painted body color) on the forward edge. This vertical bracket is held in place by a horizontal bolt (also painted body color). Remove the bolt using a 10-mm socket and store the bracket. On the "flying buttress" closest to the firewall, bend the captive nut tang downward to make room for the plastic elbow.

7.3 Bring the Air mass sensor with the air filter base installed over to the engine bay. Tilting the assembly at an angle, feed the Air mass sensor outlet into the rubber reducer sleeve already in place on the plastic elbow (install loose hose clamp first). The air flow meter assembly fits into the space just inside the shock tower, between the two "flying buttresses" of the shock tower. The extra hole and boss in the air filter base will line up with the horizontal hole you just removed the 6-mm body colored bolt from. Using the longer bolt

provided (M6 x 30-mm, Allen head), attach the air filter base/air flow meter assembly to the car using this bolt (it mounts horizontally, through the air filter base, the flying buttress, and into the Mazda captive nut on the flying buttress). Use thread-locking compound. Make sure that the electrical connector on the air flow meter is still accessible for the main wiring harness clip to be installed.

7.4 Make sure that there is no chaffing or rubbing anywhere along the plastic elbow assembly, even though it is a very tight fit. Gently reposition any brake lines that are pressing against the elbow. Make sure all joints and clamps are secure - a leak in this area will keep your car from idling correctly. However, never over tighten your clamps, they may break somewhere down the road. Use the small length of rubber hose (1/4" diameter) that is slit along its length to cover the brake line running just above the elbow. This will prevent any contact at this point, which may result in noise during operation.

7.5 Locate the 3/4" diameter idle air hose (5" length) from your kit. Attach one end to the 'large' outside fitting on the plastic elbow

Figure 7.5

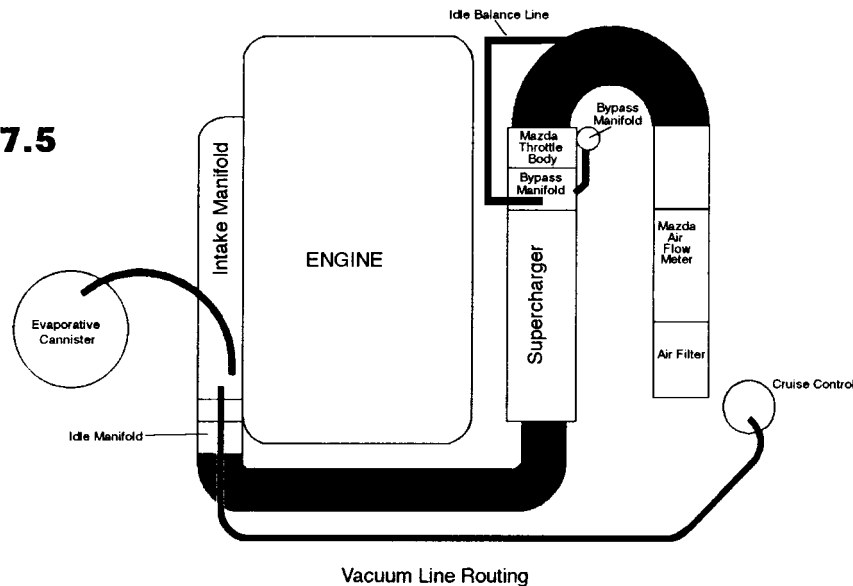

Supercharger Installation Instructions

downstream of the airflow meter (just below the brake master cylinder once the elbow is in place). Use a clamp to secure the hose to the short 3/4" nipple. Run the hose toward the front of the engine compartment, and across the engine side of the radiator, under the upper radiator hose. Using the tie-wraps provided, attach the rubber hose securely to the radiator fan shroud supports near the fan motor(s). Attach the end of the hose to the idle control (ICS) valve nipple that is aimed toward the front of the vehicle. Make sure that the hose is attached in a way that will not interfere with either fan operation or with the engine belts. The hose is supplied a bit longer than it needs to be. Feel free to trim its length if you prefer. Be careful not to pinch the hose at any point - doing so will affect your idle stability. You want to have it tie-off in a low position; the gray cross over tube will fit above this hose, hiding it in the final installation. On some cars, there might be a slight kink in the hose where it attaches to the plastic elbow nipple. This is acceptable - orient the hose so it remains open.

7.6 Install the air filter element over the air filter base. Install the waffle-patterned air filter cap and secure using the nuts provided. Use the tie-wraps provided to secure all components and keep them clear from the belt runs, exhaust manifolds, and especially the throttle cable. Re-route the air bag harness over the air filter, keeping it away from the headlight raising motor.

IMPORTANT: Secure the air bag harness with tie wraps to keep it from falling into the engine belt system or being pinched in any way.

7.7 Take the throttle body wiring harness extension as left in step #2.6 and route the body of the harness along the firewall using the bright cad plated firewall clips that originally held the throttle cable on your stock Miata. Tie-wrap the extension harness along

the firewall in at least two places. Make sure to leave enough slack on both ends to allow the engine to rock side to side without pulling on the harness. Contain any extra length in a neat fashion. Connect the female end to the throttle body at the throttle position sensor.

7.8 Find the internal restrictor taken out of your PCV hose in step #1.4. Locate the 3/8" internal diameter rubber hose from your kit and press the restrictor into this hose at least one inch. Attach this hose from the 'medium' fitting on the plastic intake elbow (near the throttle body, pointing to the engine). Cut to length and attach the other end to the camshaft cover fitting on the exhaust side. Make sure the hose does not kink at any point and that the restrictor is not left out. If you leave the small restrictor out, the engine will not idle correctly. Locate the 7/32" internal diameter idle balance hose and attach it to the 'small' fitting on the plastic elbow. Attach the other end to the unused vacuum nipple on the bypass block of the supercharger. Cut the line to the proper length, leaving some slack to allow for engine movement. Make sure the line is not pinched in any way and that it has

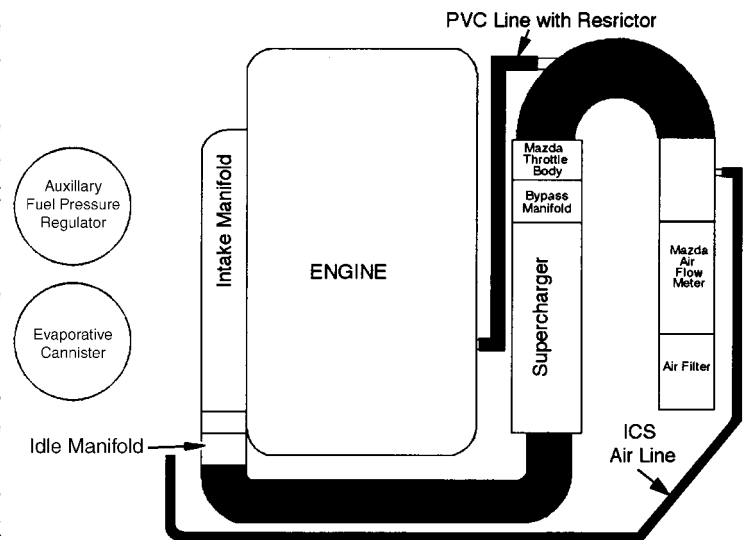

Idle Air (ICS) And PVC Line Routing

Supercharger Installation Instructions

no possibility of interfering with the throttle cable or spool. Use tie wraps as necessary to secure the line. The diagram in figure #7.5 shows the bypass actuator signal line being attached to the engine side nipple on the bypass manifold. It may be connected to the fender side nipple –either is acceptable. Connect your idle balance line to whichever vertical nipple is unused. The bypass actuator may have two nipples on its “can”. The upper one is used in this kit. The lower nipple should be left open - it is used in the GM factory installations.

7.9 Reconnect the 5 pin electrical connector to the air flow meter. Make sure the harness is not pinched at any point.

8.0 FINAL ASSEMBLY

8.1 Install the new 4-rib drive belt. This new belt will run counter-clockwise from the crankshaft, around the air conditioning compressor, up to the power steering pump, over to the right plastic idler pulley, up and over the supercharger pulley, just under the left plastic idler pulley, and back down to the crankshaft.

NOTE: Cars without air conditioning –your belt run will be similar, but the belt will simply run from the crankshaft to the power steering pump. A shorter belt has been provided.

INSTRUCTIONS FOR NON-POWER STEERING MIATA'S WITH AIR CONDITIONING

To install the supercharger belt drive in your particular situation, follow the instructions as outlined in the installation manual except for section 3.0 on Belt Drives. Since you do not have a power steering bracket to attach your lower bracket to, you will use special bracketry that we have included with your kit. Turn to figure 3.4 in the installation manual and find the note describing the bolt that will be used for the non-power steering car's lower strap bracket anchor. The Mazda idler pulley set-up for your four-rib belt has a cast iron bracket that is bolted to the engine block. This bracket

is held on by three large bolts. The lower bolt of the triangle pattern will be the one you attach our “L” bracket to. It is in the position noted in figure 3.4. This is where you will attach the small “L” bracket to the engine block using the new M10 x 50 fine thread bolt we provide. The lower strap bracket can then be attached to this “L” bracket, supporting the outside of the supercharger. For the belt drive, please remove all the adjustment hardware from the cast iron Mazda idler bracket (the idler pulley, the special mounting bolt, the vertical adjustment bolt, etc.). You will be left with just the naked iron bracket on the engine. Using the 2.5” diameter plastic idler we provide, and the M10x50 bolt, washer and nyloc nut, mount the plastic idler to the front of the Mazda cast iron bracket. Make sure to put the washer under the bolts head and to aim the bolt toward the radiator (see diagram above). Run the belt over the crank pulley, under the idler pulley, over the supercharger and around the air conditioning compressor. Push the plastic idler Downward and tighten its center bolt to properly tension the four-rib belt. If you are careful, a screwdriver can be placed in the cast iron brackets vertical slot to lever the plastic pulley downward. This will help you get the proper tension on the belt. You should have less than 1/2 inch deflection on the longest run of the belt. If you find the belt to fit too tightly, gently rock the car in fourth gear while pressing the belt onto the pulley. Watch out for your fingers.

UNDER NO CIRCUMSTANCES SHOULD YOU USE THE ENGINE STARTER TO “BUMP” THE BELT ONTO THE SUPERCHARGER. DOING SO PUTS A HIGH LOAD ON THE SUPERCHARGER BEARING AND WILL VOID YOUR WARRANTY. IT ALSO IS VERY DANGEROUS.

Loosen the pinch bolts on your relocated power steering adjustment assembly (12- mm head on pillow block pinch bolt, 14- mm head on lower front bolt). Tighten the long bolt “D”

Supercharger Installation Instructions

per figure 3.4 to achieve correct belt tension. The longest run of the belt should not deflect more than 3/8 of an inch when pressed down with around 22 pounds of thumb pressure. The tension specification is 90 pounds. Re-tighten the pillow block pinch bolt, idler bracket bolt, and the power steering pivot bolt. An easy check for proper belt tension is done by listening to your belts during warm up. If turning the steering wheel with the air conditioning on creates a squeal, then the tension is far too loose. In general, only a slight amount of black dust should appear around the super-charger nose when the tension is correct. Heavy dusting indicates excessive belt wear from a loose belt. Check your tension again after the first 500 miles - it will loosen slightly as the belt wears in. NEVER ATTEMPT TO ADJUST THE BELT WITH THE ENGINE RUNNING! Re-tighten all bolts and double-check your work.

8.2 Locate the rubber sleeves and the front cross over pipe. Check inside the cross over pipe for debris and clean it out if necessary. Install the cross over pipe between the idle air manifold (dummy throttle body now on the intake manifold) and the supercharger discharge manifold. If you find the rubber sleeves hard to slip over their respective landings, use some spray light oil such as WD40, which dries off to lubricate the situation. Do not use gasoline products or pure silicone products. The best technique for installing the cross over tube involves putting the 2.75" diameter rubber sleeve on the supercharger manifold and the 2.5" diameter sleeve on the cross over tube, and attach both with clamps. Then install the cross over tube, starting at the supercharger end first. Note that the cross over pipe goes over the radiator hose.

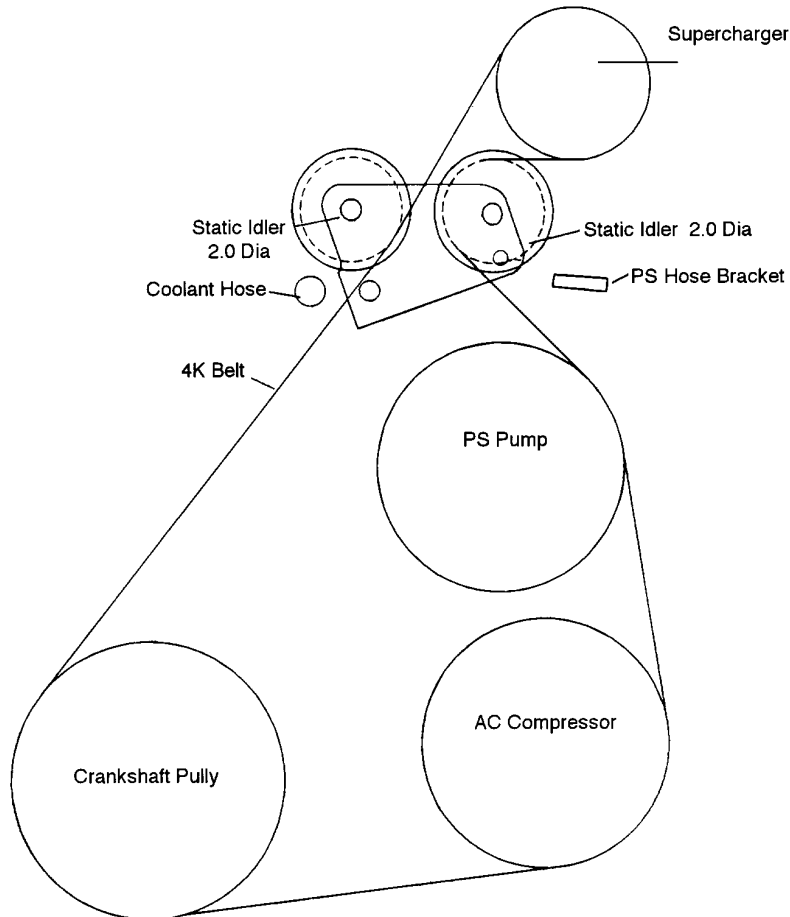

Supercharger Installation Instructions

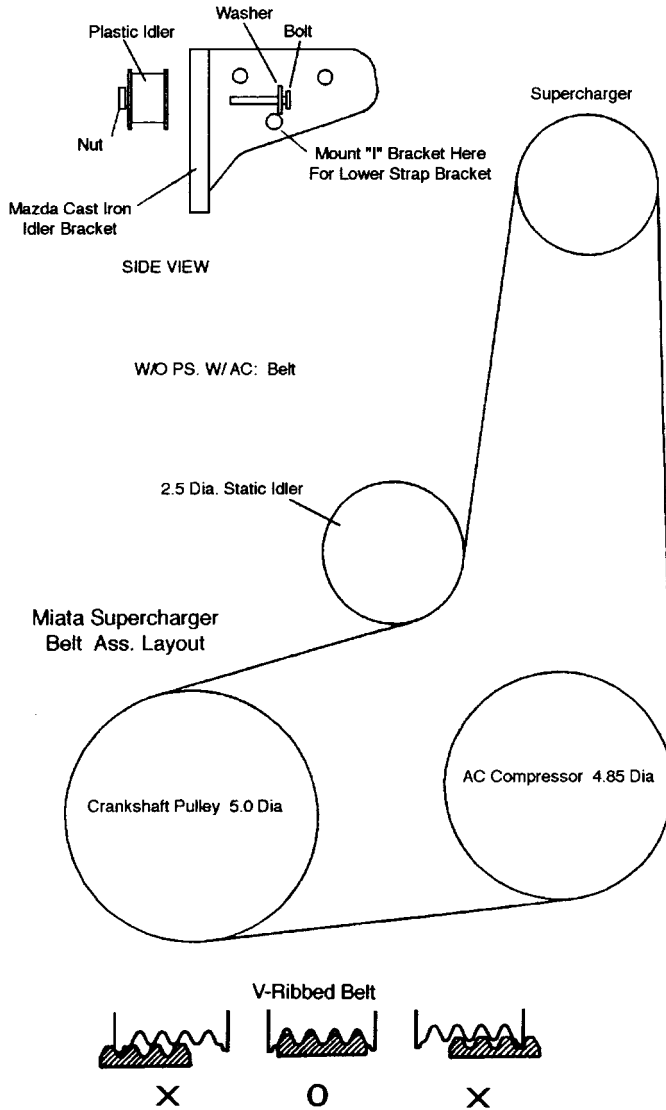

8.3 If you have cruise control, route the factory vacuum line from the cruise control back to its original position, being careful to tie-wrap it away from the engine belts or radiator fans. Remove the steel spacer from one of the mounting grommets on your stock Mazda air box. Use this 13/16" long spacer and the 6mm x 25mm hex head bolt supplied to secure your cruise control brace to the air filter base. The bolt will go vertically through the cruise control leg brace and into the small ledge with a threaded hole on the air filter base.

8.4 Once the cross over pipe is installed correctly, double-check all your pipe and tube connections. There should be no loose ends or connections. Do not over-tighten any hose clamps, but ensure that they are snug. Double check your power steering belt and supercharger belt for

8.5 Gently bend your hood prop rod so that it does not touch the cross over tube at any point. It will normally contact the tube just in front of the supercharger area. You are now ready to start your engine.

8.7 CLEARANCES IMPORTANT! MAKE SURE THAT YOU HAVE AT LEAST 3/4" INCH CLEARANCE BETWEEN ANY ENGINE MOUNTED COMPONENT AND ANY BODY MOUNTED COMPONENT. CRITICAL AREAS: BYPASS ACTUATOR TO BRAKE LINES.

The engine "rocks" strongly to the driver's side upon deceleration. If clearance is too tight, your brake lines can be gently deformed away from the supercharger bypass actuator by hand.)

SUPERCHARGER OUTLET MANIFOLD TO AIR FILTER (INCLUDING CLAMPS) ALL VACUUM LINES TO THROTTLE SPOOL AND CABLE

9.0 ENGINE ADJUSTMENTS

9.1 SUPERCHARGER BELT DRIVE ADJUSTMENT

Start your engine and observe your belt drive. The belt should line up with itself as it passes between the two plastic idlers. To put it a different way, the portion of the belt running up to the supercharger should lay directly over the portion leaving the supercharger and heading toward the power steering pulley. If the upward run is more forward or rearward than the downward run, you need to move your supercharger slightly forward or backward with respect to the crankshaft pulley. Remember

Supercharger Installation Instructions

the two bolts attaching the superchargers bracket to the cylinder head from step 6.1. You can now access these two bolts with an open-end wrench. Loosen each bolt slightly to allow for adjustment. Start the engine. You can now move the supercharger assembly slightly forward or rearward to correctly align the drive pulleys. The slots in the Supercharger mounting bracket will allow you to find the perfect alignment for the belt run.

NOTE: Do no attempt to move the supercharger with your hands with the engine running. Use an appropriate tool.

The best tool to use is a flat blade screwdriver placed between the forward bracket bolt and the front inside edge of the bracket. Move the supercharger assembly while watching the belt run the idler pulley. If you have the two bracket bolts too loose, the supercharger will be out of alignment from side to side. Make sure the two bolts are snug enough to just allow some leveraged movement. Once you have the belt running true in the center of the idler pulleys, tighten the rear bolt to secure the position. Shut off the engine and tighten the other bracket bolt securely. Recheck all mounting bolts for tightness.

9.2 IDLE ADJUSTMENT:

Restart your engine. Using the idle airscrew on your throttle body (now on the back of the supercharger), adjust your idle speed to 950 rpm after the engine is warm. This is done by backing the adjustment screw out a half turn at a time until the correct speed is achieved (counter-clockwise rotation increases idle speed). Next, turn your headlights on BRIGHT and put your heater fan on HIGH. Leave the air conditioning off. Rev the engine briskly in neutral to at least 2500 rpm and release. Notice if the idle stops at 900rpm. If it dips below this level and feels like it will stall, then recovers to 950 rpm, open the idle airscrew (counter-clockwise rotation) one tenth of a turn at a time until most of this "droop" disap-

pears. A slight droop of 100 rpm or so is acceptable and normal. More than that may create a stalling problem during driving. Turn off the lights and heater fan and double-check that your idle speed is 950 rpm.

9.3 use timing light to adjust your ignition timing to 8° before top dead center (BTDC). You have to run a jumper wire (an unfolded paper clip will do nicely) between terminals "GND" and "TEN" of your diagnostics center (located just above the driver's side shock absorber). The ignition timing is adjusted using the position sensor mounted at the firewall end of the exhaust camshaft. A 12mm box wrench will loosen the securing bolt. The 8° BTDC mark is the one just to the right of the " 10° " mark on the crankshaft pulley as viewed under a timing light.

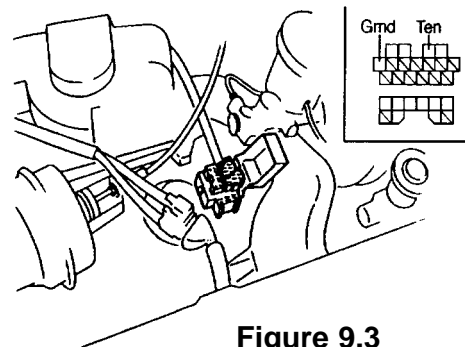
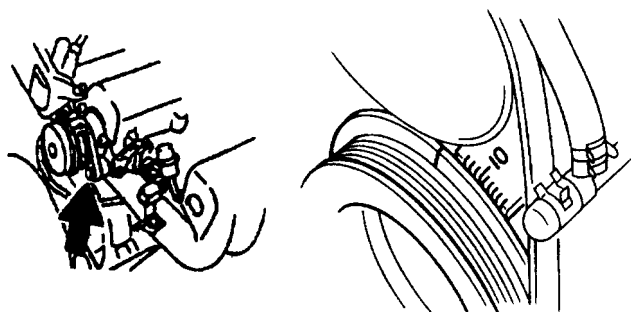

Figure 9.3



Supercharger Installation Instructions

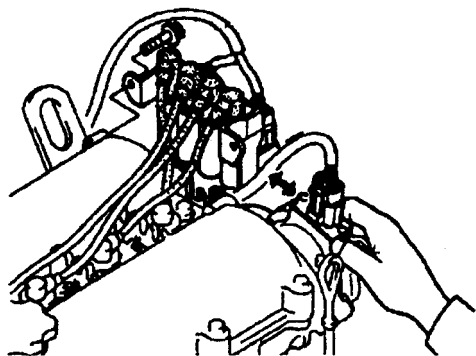

FIGURE 9.3B
MIATA 1.8 LITER TIMING ADJUSTMENT

9.5 IGNITION TIMING AND FUEL QUALITY: Your Miata supercharger kit is designed to operate on 92 Octane fuel. Make sure that any fuel you use meets this octane level using the R+M/2 method. Failure to use 92 Octane fuel will result in engine-damaging detonation. Make sure that you run your engine on 92 Octane only, which means you should completely burn up any lower octane gas in your tank and refill it with 92 octane before installing your supercharger kit. **NOTE:** If you can only find 91 octane fuel (R+M/2 method) or if your fuel is oxygenated, set your timing to 6° BTDC instead of 8°. If you live in an extremely hot area (temperatures exceeding 100°F), set your timing to 6° BTDC for an extra margin of safety. In any case, should you ever hear “pinging” or knocking from your engine when under acceleration, you should take measures to eliminate this detonation, i.e. higher-octane fuel or a further retardation in ignition timing. **NEVER CONTINUE TO OPERATE YOUR ENGINE IF YOU HEAR ANY SIGNS OF DETONATION (PINGING OR KNOCKING). YOU WILL QUICKLY MELT YOUR ENGINE DOWN!** This kit has been carefully designed to work within the stock Mazda engine parameters and no detonation will occur if the above settings and fuel are followed. The only way detonation can creep into your situation is if your engine has a mechan-

ical fault or the fuel you are using is of the incorrect octane, or if your timing is set incorrectly. It is your responsibility as the installer of this kit to insure that the supercharger has been installed according to specification.

DRIVING TIP: If you should find yourself in a situation where you cannot find high-octane fuel, you can bypass the supercharger temporarily. Note the position the bypass actuator arm is in during idle. This is the position that bypasses the boost air back into the supercharger inlet. As you blip the throttle, the actuator arm will move and close a butterfly valve inside the bypass manifold. Using a short piece of wire, fix the bypass actuator arm in the “bypass” position that it holds at idle. This will prevent boost from being developed and thus, detonation will not occur. Of course, your engine will now run like a stock Miata’s, but will be quite operable for as long as you need. When you find higher-octane fuel, simply remove the wire to release the actuator arm and the bypass will function normally, closing during acceleration, bypassing during idle and cruise. Try to run the low octane fuel out of your tank before filling up. Mixing fuels of different octane will lower the overall rating and detonation could still be a problem. You can order a Jackson Racing Boost Timing controller that retards your timing during boosted conditions. This is useful for those who can only find 91 Octane fuel or wish to increase their low-end power by advancing the static ignition timing.

9.6 Starting procedure: Start your engine as you would a standard Miata. Remember to bring the engine up to operating temperature (as indicated by your water temperature gauge) before running it hard. Full boost on a cold engine will greatly increase your engine wear.

9.7 Oil changes: we suggest you use synthetic oil such as Mobile 1 and change it regularly

Supercharger Installation Instructions

(5000 miles maximum). If you use a mineral oil, change it every 2500 miles. While your supercharger does not use any engine oil for its lubrication, your engine will be working a little harder with the addition of a supercharger. The synthetic oil provides an extra measure of protection, but is not necessary for safe and reliable operation.

9.8 Breaking-in: Your supercharger will work perfectly from the first time you fire it up. However, it does need about 500 miles to fully seat the rotors. Up to that time, you may notice a slight noise coming from the supercharger at idle. This is normal.

9.9 Performance: You will notice that your engine runs stronger during cold days than on very hot ones. This is due to the nature of the internal combustion engine. When the air is cold, the engine receives a denser charge of air, thus more power can be produced. While this is true with any engine, the supercharger amplifies this cold air benefit.

10.0 LONG TERM MAINTENANCE

10.1 BELTS

The only item to watch with your supercharger kit will be the belt tension for the supercharger drive. If you have a tension gauge for a poly-vee belt, the tension is to be 90 pounds. Without a gauge, look for less than 1/4" deflection on the long run of the belt. If you see a large accumulation of belt dust on your supercharger, it is an indication that your belt is slipping. A slight amount of belt dust is normal. **CHECKING YOUR BELT FOR WEAR:** As the belt wears, small cracks will form in each of the ribs on the inside run of the belt. Replace your belt when you can count six cracks within one inch of length (six cracks total from all ribs combined).

10.3 Every six months or so, check your hose clamps for correct tension. The rubber hoses will take a set and the clamps may not be

holding as tight. Also check all mounting bolts and nuts, particularly the throttle cable anchor bracket.

10.4 Your air filter is a long-life unit needing service only every 15,000 miles. To clean, you can wash the filter element in soap and water. Use a dish detergent soap such as Dawn, etc. Rinse thoroughly and allow to dry. Wet the filter element with a light application of ATF (automatic transmission fluid). Alternatively, a special cleaning kit is available (901-970)

10.5 At every oil change, lubricate the bypass actuator arm contact point and shaft bushing with light grease to insure long life - these parts are exposed to under hood dirt and grime.

TROUBLESHOOTING

SYMPTOM: Engine cranks but will not start.

PROBABLE CAUSES: Airflow meter disconnected; Idle air line open; Low battery voltage.

CURE: Double check that seven pin to airflow meter is well connected. Re-check the 3/4" ICS line and the PCV line to see that they are not leaking. Use a known good battery to "jump" the Miata's battery. It is possible to have enough voltage to crank a Miata but not enough to correctly run the engine's control computer.

SYMPTOM: No power during boost.

PROBABLE CAUSES: Cross over tube loose; Idle Compensator not connected/not functioning

CURE: Check fuel lines for kinking. Check the cross over tube to see that it is well connected at both ends. Check Idle Compensator electrical connections, check its resistance; should be approximately 22k ohms

SYMPTOM: Unstable Idle.

PROBABLE CAUSE: Idle airscrew set incorrectly; Restrictor left out in step #7.8; air leak in intake track.

Supercharger Installation Instructions

CURE: Re-check restrictor. Check idle adjustment procedure in step 8.1 above. Check for air leaks - vacuum at idle should be at least 17.7 in Hg.

HELP: If you experience any problems with your kit during installation or operation, contact your retailer or Jackson Racing at 1-888-888-4079.

11.0 FURTHER MODIFICATIONS

Now that your Miata has a stronger engine, there are a few changes you might want to make to the rest of the car to improve its performance. The following are not required for your supercharged Miata, but are presented as tuning hints for a better all-around car.

When it comes time to put in a new clutch, we recommend the Jackson Racing Stage 1 clutch kit. While your new supercharger and the standard Mazda clutch work well together, it is a good idea to step up to the Jackson Racing unit when you are changing your clutch.

Now is the time to upgrade your suspension. Jackson Racing sway bars will tighten your steering response. If your Miata has over 30,000 miles on it, a new set of Tokico shocks will also help. The Tokico shock and Jackson Racing Sport spring lower the car 35mm. This combination yields better handling with out the harsh ride of competition springs. Have your car aligned afterward (driver's equivalent weight in the driver's seat) to factory specifications after any suspension changes.

A Jackson Racing Performance Cat-back exhaust will make your supercharged Miata that much faster. Since you are now flowing 300 cubic feet per minute through a muffler designed for 177 cfm, an improvement can be made.

WARRANTY: The supercharger unit itself carries a two-year or 100,000 mile warranty (for the original purchaser of the kit) against defects in material and workmanship. No other warranties apply. This warranty is void if the subject vehicle is used in any racing activities of any sort.